

Norky Wei

WhatsApp & Facebook: +86 188 3028 9136

Wechat: 0086 183 3017 3287

Fax: 0086 312 3085383

Tel: 0086 312 6795175

Email:norky@deponpump.cn



# SUBMERSIBLE SEWAGE PUMPS

---

# 目 录

## CONTENTS

---

<b>产品用途</b> Purpose	1
<b>型号意义</b> Model meaning	1
<b>使用条件</b> Conditions of use	1
<b>旋转方向</b> Rotating direction	1
<b>结构说明</b> Structures description	2
<b>WQ型结构图</b> WQ type structure drawing	4
<b>WQ型泵型谱图</b> WQ type atlas of style	5
<b>WQ型泵性能参数</b> WQ type pump performance	6
<b>WQ型泵安装方式</b> WQ type pump installation	12
<b>WQ型泵安装尺寸图表</b> WQ type pump dimension drawing and table	14
<b>WQ型泵自动耦合安装尺寸表</b> WQ type pump auto-coupled installation dimensions table	16
<b>潜水排污泵导轨长度与池深关系一览表</b> Lead rail length and pool depth table	25
<b>WQ型泵固定式安装尺寸表</b> WQ type pump fixed installation dimensions table	26
<b>使用、检查与维修</b> External and installation dimension table	34
<b>故障原因及排除方法</b> Failures causes and troubleshooting	36
<b>管路损耗参考表</b> Reference table for pipeline loss	37

---

### 产品用途 Purpose

WQ系列潜水排污泵主要用于市政工程、工业建筑、宾馆、医院、人防、矿山等行业，可用于排送带固体颗粒及各种长纤维的污水、废水、雨水和城市生活用水。

WQ series submersible sewage pump is mainly used for municipal works, industrial buildings, hotels, hospitals, civil air defence, mines etc. Trades to drain off the sewage, waste water, rainwater and living water in cities containing Solid grains and various long fabrics.

### 型号意义 Model meaning

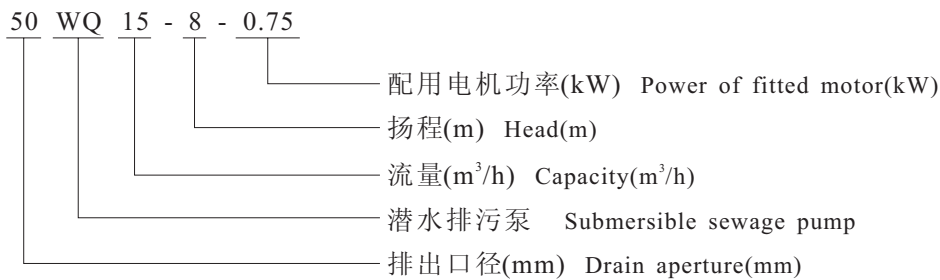

### 使用条件 Conditions of use

- 1、介质温度不应超过40°C，介质密度≤1200Kg/m<sup>3</sup>，PH值在5-9范围内。
- 2、运行时泵不得低于最低液位，参见安装尺寸图中的“▶最低液位”（含自动冷却系统）。▽为无自动冷却系统时最低液位。
- 3、额定电压为380V，额定频率为50Hz。在额定电压和额定频率的偏差不大于 5%时，电机才能正常运行。
- 4、通过泵的固体颗粒的最大直径不得大于泵体排出口直径的50%。

1. The medium temperature should not be over 40°C, the density 1200Kg/m<sup>3</sup>, and the PH value within 5-9.
2. During running, the pump must not be lower than the lowest liquid level, see "▶lowest liquid level" in the drawing of installation dimensions(covering the automatic cooling system), ▽ means lowest liquid level without no automatic cooling system.
3. Rated voltage 380V, rated frequency 50Hz. The motor can run successfully only under the condition the deviations of both rated voltage and frequency are not over 5%.
4. The maximum diameter of the solid grain going through the pump has not to be larger than 50% of that of the pump outlet.

### 旋转方向 Rotating direction

从泵吸入口看，叶轮为逆时针方向旋转。

The impeller rotates CCW as viewed from the suction.

## 结构说明 Structures description

### 轴 承:

选用进口SKF轴承或NTN轴承。其合理的轴承配置，能够延长泵的使用寿命。

### 冷 却:

内装的冷却系统，不论电机是在液面上还是在液面下，均能使泵正常工作。抽送液体的一部分从泵体循环至冷却筒和机壳之间带走电机产生的热量。需要外部冷却时，冷却套可与泵体隔开，并与单独的冷却系统相连。

### 电 机:

电机为F级绝缘，最高工作温度为155°C，有效的密封使电机防护等级为IPX8。

### 机械密封:

选用德国博格曼机械密封，两道机械密封串联相互独立工作。使电机与泵密封地隔开，为电机提供双重保护。

泵侧材质为碳化钨/碳化钨，电机侧材质为石墨/碳化硅。

### 油 室:

油可润滑并冷却机械密封，并能阻止液体渗透至电机的附加安全功能。内留的一定量空气可降低油室内压力的积聚升高。

### 叶 轮:

经过优化设计，以其最佳的流量和速度以最大效率输送液体使其不产生堵塞。每一个工况点都有相适应的叶轮可供选择。

根据抽送的介质，有单流道、双流道、三叶片叶轮可供选择。

### 泵 体:

采用CAD/CAM技术，使泵体具有最高的效率和最小的磨损。

### Bearing:

Imported SKF or NTN bearing, which, with a reasonable configuration, can extend the duration of the pump.

### Cooling:

The built-in cooling system can have the pump normally work whether the motor is on or under the liquid surface. A part of the liquid is extracted to bring out the heat produced by the motor from the pump circulation to the cooling barrel and to the pump casing and, when external cooling is required, the cooling sleeve may be separated from the pump casing and individually connected to the cooling system.

### Motor:

Of F class insulation, max. working temperatures 155°C, and of a protective grade IPX8 with the effective seal.

### Mechanical seal:

Use Bogman mechanical seal of Germany, two ways of the seal are in series with each other and individually work to separate the motor from the pump seal to provide the motor with a dual protection.

The sealing material on the pump side is tungsten carbide/tungsten carbide while on the motor side, graphite/silicon carbide.

### Oil chamber:

Oil can lubricate and cool the mechanical seal and realize the attached function of safety by preventing liquid from penetrating into the motor. The air of a certain amount left inside of the chamber can lower the pressure accumulatively raised.

### Impeller:

With the optimized design, the impeller will not be blocked up when to transport liquid with its optimum flow and rate and the maximum efficiency. There are suitable impellers at choice for every point of working condition.

There are single-geat, dual-geat and three-blade impellers available at choice per the medium to be extracted.

### Pump casing:

Use the know-how of CAD/CAM to make it of max. efficiency and min wearability.

### 轴:

泵与电机同轴，轴端密封装置，使轴不与抽送介质相接触，保护轴不受腐蚀。

转轴悬伸设计得尽量短，降低转轴的挠度，并减小振动，延长机械密封和轴承的使用寿命，降低运行噪音。

### 监控系统:

定子内嵌有三个串联的 控开关。常温时为“常闭”状态，当定子温度达到125℃时，开关打开。

油室内装有漏水探头，用作漏水检测。当泵侧机械密封泄漏，油室内的油水比例达到一定浓度，油水探头就发出报警信号(指示灯亮)并自动切断电源，使泵停止工作。

维修人员应及时更换油室内的油，并检查和更换泵侧机械密封。

电机功率不低于30kW的泵，接线腔内均装有漏水探头，检测电缆密封是否泄漏。

### 浮子开关:

当电机侧机械密封泄漏、液体进入浮子开关室、渗入液体达到一定高度时，浮子开关会发出报警信号(指示灯亮)并停泵，维修人员应进行检修并更换电机侧机械密封。

电控柜有对电机缺相进行检测的功能，以防缺相烧坏电机。

### Shaft:

The pump is coaxial with the motor and the sealing device on the end of the shaft prevents against contacting with the medium to protect is from corrosion.

The as short as possible designed stretched rotating shaft can be reduced with its deflection and vibration, extend the duration of both mechanical seal and bearing and lower the noise at running.

### Monitor system:

Inside of the stator there are three inlaid series heat-control switches, which are in the state of "N.O." at the normal temperature and opened when the temperature on the stator gets to 125℃.

A water-leakage probe is mounted inside the oil chamber to check water leakage and it will give a warning signal(the indicator lights), when the mechanical seal on the pump side leaks and the oil-water ratio in the oil chamber reaches a certain concentration, to automatically cut off the power to stop the work of the pump.

Serviceman should replace the oil timely and check the mechanical seal on the pump side and replace it it necessary.

All the wiring box of the motor with a power not lower than 30kW is mounted with a leakage probe to check if a leak with the cable seal.

### Float switch:

The float switch will give a warning signal(the indicator lights), when leakage occurs on the mechanical seal on the motor side, the liquid goes into the switch room and reaches a certain height, to stop the pump. Serviceman should check the mechanical seal and replace it if necessary.

The function to check if the motor lack of phase is available with the electric control cabinet so as to prevent it from burning due any lack of phase.

WQ型结构图 WQ type structure drawing

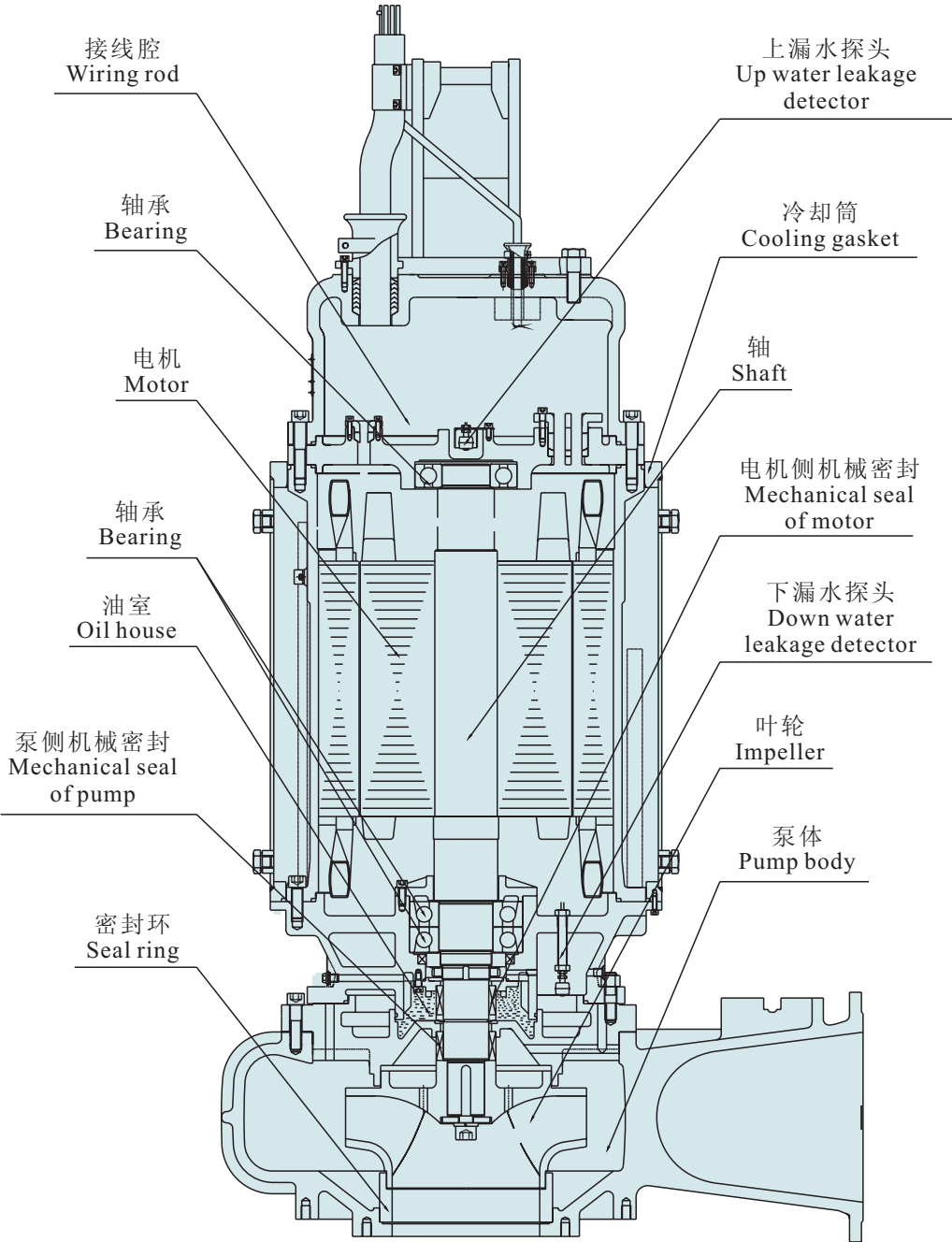

WQ型泵型谱图 WQ type atlas of style

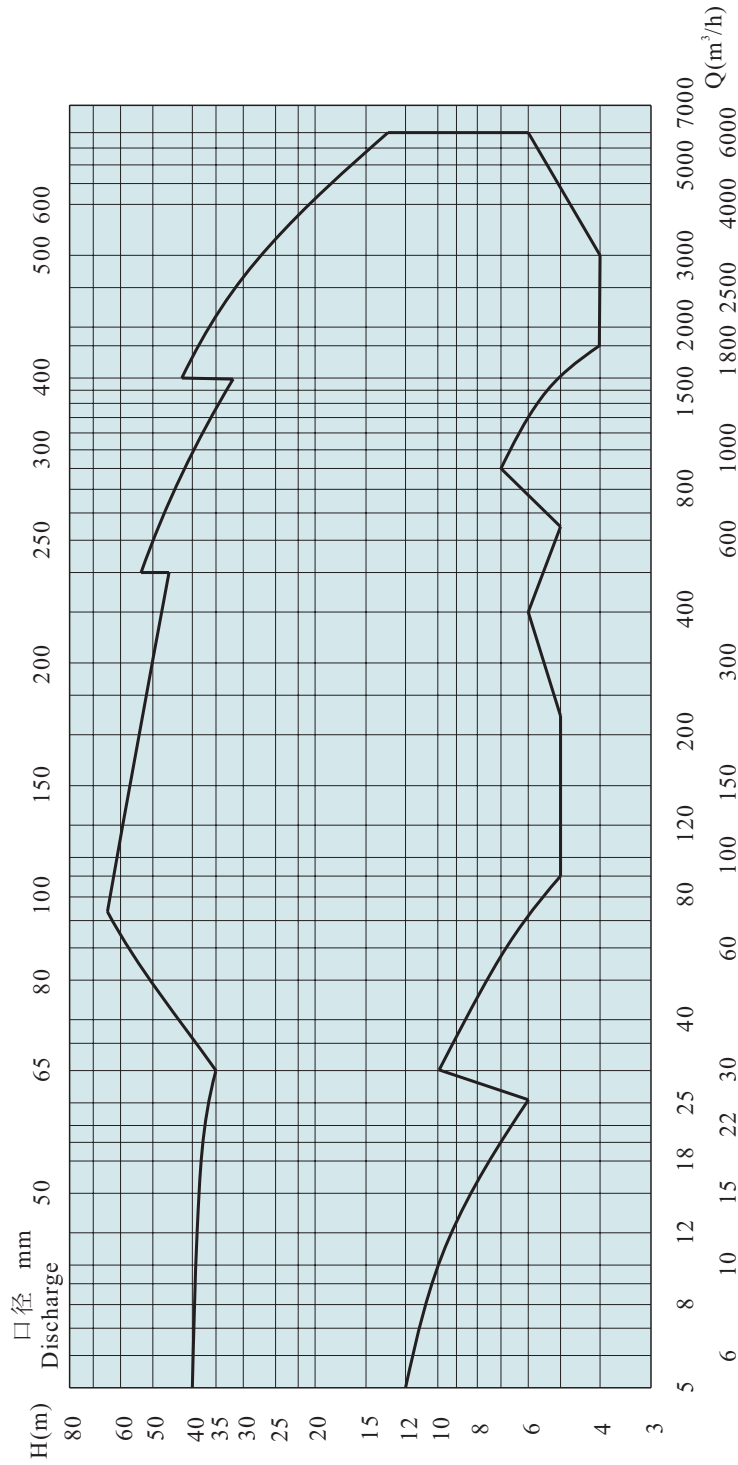

## WQ型泵性能参数 WQ type pump performance

序号 No.	型号 Type	排出口径 Outlet diameter (mm)	流量 Capacity		扬程 Head (m)	转速 Speed (r/min)	功率 Power (kW)	效率 Efficiency (%)	重量 Weight (Kg)
			(m <sup>3</sup> /h)	(L/s)					
1	50WQ15-8-0.75	50	10	2.8	10	2825	0.75	48	30
			15	4.2	8				
			20	5.6	7				
2	50WQ15-12-1.1	50	10	2.8	14	2825	1.1	48	32
			15	4.2	12				
			20	5.6	10				
3	50WQ15-16-1.5	50	10	2.8	18	2840	1.5	48	40
			15	4.5	16				
			20	6.9	10				
4	50WQ15-22-2.2	50	10	2.8	25	2840	2.2	48	45
			15	4.2	22				
			20	6.9	16				
5	50WQ15-30-3	50	10	2.8	33	2880	3	45	55
			15	4.2	30				
			20	6.9	20				
6	50WQ25-25-4	50	20	5.6	28	2880	4	43	65
			25	6.9	25				
			40	11.1	18				
7	50WQ25-32-5.5	50	20	5.6	35	1440	5.5	43	90
			25	6.9	32				
			40	11.1	25				
8	50WQ25-36-7.5	50	20	5.6	38	1440	7.5	43	105
			25	6.9	36				
			40	11.1	33				
9	65WQ30-10-2.2	65	20	5.6	12	1420	2.2	50	55
			30	8.3	10				
			45	12.5	8				
10	65WQ30-15-3	65	20	5.6	17	1420	3	50	65
			30	8.3	15				
			45	12.5	12				
11	65WQ30-22-4	65	20	5.6	24	1440	4	44	75
			30	8.3	22				
			45	12.5	16				
12	65WQ30-30-5.5	65	20	5.6	32	1440	5.5	44	100
			30	8.3	30				
			45	12.5	22				
13	65WQ30-35-7.5	65	20	5.6	37	1440	7.5	44	115
			30	8.3	35				
			45	12.5	30				
14	80WQ50-8-2.2	80	40	11.1	10	1420	2.2	56	65
			50	13.9	8				
			75	20.8	6				
15	80WQ50-10-3	80	40	11.1	13	1420	3	56	75
			50	13.9	10				
			75	20.8	8				
16	80WQ50-15-4	80	40	11.1	18	1440	4	55	85
			50	13.9	15				
			75	20.8	10				
17	80WQ50-20-5.5	80	40	11.1	23	1440	5.5	48	110
			50	13.9	20				
			75	20.8	16				
18	80WQ50-21-7.5	80	40	11.1	28	1440	7.5	48	125
			50	13.9	25				
			75	20.8	21				
19	80WQ50-35-11	80	40	11.1	40	2900	11	48	180
			50	13.9	35				
			75	20.8	27				
20	80WQ50-40-15	80	40	11.1	42	2900	15	46	205
			50	13.9	40				
			75	20.8	37				

WQ SERIES SUBMERSIBLE SEWAGE PUMP

WQ型泵性能参数 WQ type pump performance

序号 No.	型号 Type	排出口径 Outlet diameter (mm)	流量 Capacity		扬程 Head (m)	转速 Speed (r/min)	功率 Power (kW)	效率 Efficiency (%)	重量 Weight (Kg)
			(m³/h)	(L/s)					
21	100WQ80-7-3	100	65 80 120	18.1 22.2 33.3	8 7 5	1420	3	62 64 60	85
22	100WQ80-10-4	100	65 80 120	18.1 22.2 33.3	12 10 7	1440	4	62 64 62	95
23	100WQ80-13-5.5	100	65 80 120	18.1 22.2 33.3	15 13 10	1440	5.5	58 64 67	120
24	100WQ80-18-7.5	100	65 80 120	18.1 22.2 33.3	21 18 13	1440	7.5	58 64 67	135
25	100WQ80-24-11	100	65 80 120	18.1 22.2 33.3	28 24 20	2900	11	58 64 67	190
26	100WQ80-32-15	100	65 80 120	18.1 22.2 33.3	35 32 25	2900	15	54 58 62	215
27	100WQ80-36-18.5	100	65 80 120	18.1 22.2 33.3	40 36 30	2900	18.5	50 55 60	280
28	100WQ80-40-22	100	65 80 120	18.1 22.2 33.3	45 40 35	2900	22	50 55 60	290
29	150WQ150-7-5.5	150	100 150 220	27.8 41.7 61.1	9 7 5	1440	5.5	63 72 70	130
30	150WQ150-10-7.5	150	100 150 220	27.8 41.7 61.1	12 10 7	1440	7.5	63 72 70	150
31	150WQ150-15-11	150	100 150 220	27.8 41.7 61.1	18 15 11	1460	11	67 72 68	215
32	150WQ150-20-15	150	100 150 220	27.8 41.7 61.1	23 20 17	1460	15	60 68 64	240
33	150WQ150-25-18.5	150	100 150 220	27.8 41.7 61.1	28 25 19	1470	18.5	60 68 64	300
34	150WQ150-30-22	150	100 150 200	27.8 41.7 55.6	33 30 25	1470	22	60 65 68	320
35	150WQ150-40-30	150	100 150 200	27.8 41.7 55.6	42 40 33	1470	30	60 65 68	580
36	150WQ150-45-37	150	100 150 200	27.8 41.7 55.6	47 45 38	1470	37	55 62 65	650
37	150WQ150-50-45	150	100 150 200	27.8 41.7 55.6	52 50 47	1470	45	55 62 65	750
38	150WQ100-60-55	150	80 100 150	22.2 27.8 41.7	62 60 56	1470	55	53 60 63	850
39	200WQ300-7-11	200	250 300 400	69.4 83.3 111.1	8 7 6	1460	11	72 74 69	280
40	200WQ300-10-15	200	250 300 400	69.4 83.3 111.1	11 10 8	1460	15	72 74 69	300

## WQ型泵性能参数 WQ type pump performance

序号 No.	型号 Type	排出口径 Outlet diameter (mm)	流量 Capacity		扬程 Head (m)	转速 Speed (r/min)	功率 Power (kW)	效率 Efficiency (%)	重量 Weight (Kg)
			(m <sup>3</sup> /h)	(L/s)					
41	200WQ300-13-18.5	200	250	69.4	15	1470	18.5	66	370
			300	83.3	13			68	
			400	111.1	10			65	
42	200WQ300-15-22	200	250	69.4	17	1470	22	66	380
			300	83.3	15			68	
			400	111.1	13			65	
43	200WQ300-20-30	200	250	69.4	22	980	30	66	650
			300	83.3	20			67	
			400	111.1	17			67	
44	200WQ300-25-37	200	250	69.4	27	980	37	66	720
			300	83.3	25			67	
			400	111.1	30			68	
45	200WQ400-27-45	200	250	69.4	35	1480	45	65	850
			400	111.1	27			74	
			500	138.9	24			78	
46	200WQ400-34-55	200	250	69.4	39	1480	55	65	950
			400	111.1	34			74	
			500	138.9	30			78	
47	200WQ400-40-75	200	250	69.4	44	1480	75	62	1300
			400	111.1	40			70.5	
			500	138.9	35			72	
48	200WQ400-48-90	200	250	69.4	50	1480	90	62	1420
			400	111.1	48			70.5	
			500	138.9	44			72	
49	250WQ400-7-15	250	300	83.3	9	1460	15	75	450
			400	111.1	7			69	
			600	166.7	5			62	
50	250WQ400-10-18.5	250	300	83.3	12	1470	18.5	68	550
			400	111.1	10			75	
			600	166.7	7			70	
51	250WQ400-13-22	250	300	83.3	16	1470	22	68	580
			400	111.1	13			73	
			600	166.7	9			60	
52	250WQ500-10-30	250	400	111.1	15	980	30	70	700
			500	138.9	12			72	
			700	194.4	8			78	
53	250WQ500-16-37	250	400	111.1	18	980	37	70	780
			500	138.9	16			72	
			700	194.4	14			78	
54	250WQ500-20-45	250	400	111.1	22	980	45	70	1050
			500	138.9	20			72	
			700	194.4	16			78	
55	250WQ500-25-55	250	400	111.1	28	980	55	72	1115
			500	138.9	25			74	
			700	194.4	19			72	
56	250WQ600-28-75	250	500	138.9	31	1480	75	70	1480
			600	166.7	28			73	
			800	222.2	23			75	
57	250WQ600-34-90	250	500	138.9	37	1480	90	70	1580
			600	166.7	34			73	
			800	222.2	27			75	
58	250WQ600-40-110	250	500	138.9	43	1480	110	68	1650
			600	166.7	40			70	
			800	222.2	33			73	
59	250WQ600-50-132	250	500	138.9	53	1480	132	68	1710
			600	166.7	50			70	
			800	222.2	40			73	
60	300WQ600-6-18.5	300	500	138.9	7	1470	18.5	69	650
			600	166.7	6			65	
			750	208.3	5			61	

WQ SERIES SUBMERSIBLE SEWAGE PUMP

WQ型泵性能参数 WQ type pump performance

序号 No.	型号 Type	排出口径 Outlet diameter (mm)	流量 Capacity		扬程 Head (m)	转速 Speed (r/min)	功率 Power (kW)	效率 Efficiency (%)	重量 Weight (Kg)
			(m³/h)	(L/s)					
61	300WQ600-7-22	300	500	138.9	8	1470	22	69 65 61	660
			600	166.7	7				
			750	208.3	6				
62	300WQ700-11-30	300	550	152.8	13	980	30	72 78 77	780
			700	194.4	11				
			1000	277.8	8				
63	300WQ700-14-37	300	550	152.8	16	980	37	72 78 77	880
			700	194.4	14				
			1000	277.8	10				
64	300WQ700-16-45	300	550	152.8	18	980	45	72 78 77	1150
			700	194.4	16				
			1000	277.8	12				
65	300WQ700-19-55	300	550	152.8	21	980	55	70 75 73	1215
			700	194.4	19				
			1000	277.8	14				
66	300WQ1000-20-75	300	800	222.2	23	990	75	75 82 80	1530
			1000	277.8	20				
			1400	388.9	15				
67	300WQ1000-24-90	300	800	222.2	27	990	90	75 82 80	1650
			1000	277.8	24				
			1400	388.9	18				
68	300WQ1000-28-110	300	800	222.2	31	1480	110	75 82 80	1720
			1000	277.8	28				
			1400	388.9	20				
69	300WQ1000-35-132	300	800	222.2	38	1480	132	75 80 82	1800
			1000	277.8	35				
			1400	388.9	27				
70	350WQ1200-6-30	350	1000	277.8	7	730	30	75 72 70	850
			1200	333.3	6				
			1500	416.7	5				
71	350WQ1200-8-37	350	1000	277.8	9	740	37	76 75 70	950
			1200	333.3	8				
			1500	416.7	6				
72	350WQ1100-10-45	350	900	250	11	740	45	67 70 68	1250
			1100	305.6	10				
			1500	416.7	7				
73	350WQ1100-12-55	350	900	250	14	740	55	69 71 66	1320
			1100	305.6	12				
			1500	416.7	8				
74	350WQ1100-16-75	350	900	250	19	980	75	70 75 72	1650
			1100	305.6	16				
			1500	416.7	12				
75	350WQ1100-20-90	350	900	250	24	980	90	70 75 72	1770
			1100	305.6	20				
			1500	416.7	15				
76	350WQ1100-25-110	350	900	250	30	980	110	72 76 73	1840
			1100	305.6	25				
			1500	416.7	18				
77	350WQ1100-30-132	350	900	250	35	980	132	72 75 79	1920
			1100	305.6	30				
			1500	416.7	24				
78	350WQ1100-36-160	350	900	250	40	980	160	70 75 80	2700
			1100	305.6	36				
			1500	416.7	28				
79	350WQ1500-30-185	350	1200	333.3	35	980	185	75 80 77	2800
			1500	416.7	30				
			2000	555.6	24				
80	350WQ1500-32-200	350	1200	333.3	38	740	200	75 80 78	2850
			1500	416.7	32				
			2000	555.6	25				

## WQ型泵性能参数 WQ type pump performance

序号 No.	型号 Type	排出口径 Outlet diameter (mm)	流量 Capacity		扬程 Head (m)	转速 Speed (r/min)	功率 Power (kW)	效率 Efficiency (%)	重量 Weight (Kg)
			(m <sup>3</sup> /h)	(L/s)					
81	350WQ1500-35-220	350	1200 1500 2000	333.3 416.7 555.6	40 35 27	740	220	75 80 78	3050
82	350WQ1500-40-250	350	1200 1500 2000	333.3 416.7 555.6	42 40 33	740	250	78 80 82	3250
83	350WQ1800-40-280	350	1400 1800 2600	388.9 500.0 722.2	42 40 33	740	280	78 80 82	3450
84	350WQ1800-43-315	350	1400 1800 2600	388.9 500.0 722.2	48 43 35	740	315	78 80 82	3650
85	350WQ1800-46-355	350	1400 1800 2600	388.9 500.0 722.2	50 46 38	740	355	78 80 82	3950
86	400WQ1500-5-30	400	1200 1500 2000	333.3 416.7 555.6	6 5 3	730	30	75 72 65	960
87	400WQ1500-6-37	400	1200 1500 2000	333.3 416.7 555.6	7 6 4.5	740	37	75 72 65	1020
88	400WQ1500-8-45	400	1200 1500 2000	333.3 416.7 555.6	10 8 6	740	45	78 80 78	1350
89	400WQ1500-10-55	400	1200 1500 2000	333.3 416.7 555.6	12 10 7	740	55	78 82 78	1470
90	400WQ1500-12-75	400	1200 1500 2000	333.3 416.7 555.6	14 12 9	990	75	75 78 72	1740
91	400WQ1500-15-90	400	1200 1500 2000	333.3 416.7 555.6	18 15 12	990	90	75 78 80	1860
92	400WQ1500-18-110	400	1200 1500 2000	333.3 416.7 555.6	21 18 14	990	110	70 78 75	1930
93	400WQ1500-22-132	400	1200 1500 2000	333.3 416.7 555.6	25 22 17	990	132	70 75 80	2020
94	400WQ2000-20-160	400	1500 2000 2800	416.7 555.6 777.8	23 20 15	990	160	75 80 77	2750
95	400WQ2000-23-185	400	1500 2000 2800	416.7 555.6 777.8	25 23 17	990	185	75 80 77	2800
96	400WQ2000-25-200	400	1500 2000 2800	416.7 555.6 777.8	30 25 19	745	200	75 80 78	2850
97	400WQ2000-28-220	400	1500 2000 2800	416.7 555.6 777.8	35 28 21	745	220	75 80 78	3050
98	400WQ2000-32-250	400	1500 2000 2800	416.7 555.6 777.8	38 32 25	745	250	78 80 82	3250
99	400WQ2000-36-280	400	1500 2000 2800	416.7 555.6 777.8	43 36 27	745	280	78 80 82	3450
100	400WQ2000-40-315	400	1500 2000 2800	416.7 555.6 777.8	44 40 35	740	315	78 80 82	3700
101	400WQ2000-45-355	400	1400 1800 2600	388.9 500.0 722.2	47 45 38	740	355	78 80 82	4050

## WQ SERIES SUBMERSIBLE SEWAGE PUMP

### WQ型泵性能参数 WQ type pump performance

序号 No.	型号 Type	排出口径 Outlet diameter (mm)	流量 Capacity		扬程 Head (m)	转速 Speed (r/min)	功率 Power (kW)	效率 Efficiency (%)	重量 Weight (Kg)
			(m³/h)	(L/s)					
102	500WQ2000-7-55	500	1500	416.7	10	740	55	80	1950
			2000	555.6	7			76.2	
			3000	833.3	4			68	
103	500WQ2200-8-75	500	1800	500	10	740	75	75	2150
			2200	611.1	8			70	
			3000	833.3	5			65	
104	500WQ2200-10-90	500	1800	500	13	990	90	78	1920
			2200	611.1	10			72	
			3000	833.3	7			68	
105	500WQ2200-12-110	500	1800	500	15	990	110	75	1990
			2200	611.1	12			72	
			3000	833.3	8			68	
106	500WQ2200-15-132	500	1800	500	17	990	132	70	2070
			2200	611.1	15			75	
			3000	833.3	10			68	
107	500WQ3000-11-132	500	2000	555.6	14	745	132	78	2210
			3000	833.3	11			75	
			4000	1111.1	8			72	
108	500WQ3000-13-160	500	2000	555.6	21	745	160	78	2900
			3000	833.3	13			75	
			4000	1111.1	9			72	
109	500WQ3000-15-185	500	2000	555.6	22	745	185	75	2950
			3000	833.3	15			72	
			4000	1111.1	11			70	
110	500WQ3000-16-200	500	2000	555.6	23	745	200	75	3000
			3000	833.3	16			72	
			4000	1111.1	12			70	
111	500WQ3000-18-220	500	2000	555.6	26	745	220	70	3200
			3000	833.3	18			75	
			4000	1111.1	14			73	
112	500WQ3000-21-250	500	2000	555.6	29	745	250	70	3400
			3000	833.3	21			77	
			4000	1111.1	16			75	
113	500WQ3000-24-280	500	2000	555.6	32	745	280	70	3600
			3000	833.3	24			77	
			4000	1111.1	18			75	
114	600WQ3000-8-110	600	2500	694.4	10	590	110	70	2900
			3000	833.3	8			68	
			4000	1111.1	6			65	
115	600WQ3000-10-132	600	2500	694.4	12	590	132	70	3000
			3000	833.3	10			75	
			4000	1111.1	8			72	
116	600WQ4000-10-160	600	3000	833.3	13	745	160	78	3000
			4000	1111.1	10			75	
			5000	1388.9	8			73	
117	600WQ4000-11-185	600	3000	833.3	15	745	185	78	3050
			4000	1111.1	11			75	
			6000	1666.7	6			65	
118	600WQ4000-12-200	600	3000	833.3	16	745	200	75	3100
			4000	1111.1	12			72	
			6000	1666.7	7			65	
119	600WQ4000-14-220	600	3000	833.3	18	745	220	77	3300
			4000	1111.1	14			75	
			6000	1666.7	9			72	
120	600WQ4000-16-250	600	3000	833.3	21	745	250	75	3500
			4000	1111.1	16			78	
			6000	1666.7	10			73	
121	600WQ4000-18-280	600	3000	833.3	23	745	280	75	3750
			4000	1111.1	18			77	
			6000	1666.7	11			72	
122	600WQ4000-20-315	600	3000	833.3	25	745	315	75	4000
			4000	1111.1	20			77	
			6000	1666.7	13			73	

## WQ型泵安装方式 WQ type pump installation method

## 1、自动耦合式安装

## Auto-coupled installation

泵沿导杆放下, 自动连接至排出管道系统。安装建筑费用极少, 维修费用降低。

The pump is placed down along with the guide rod and automatically connected to the drainage pipeline system.

Less cost for mounting and lowering the cost for repair.

耦合装置安装原理图

SCHEMATIC DRAWING OF COUPLING DEVICE INSTALLATION

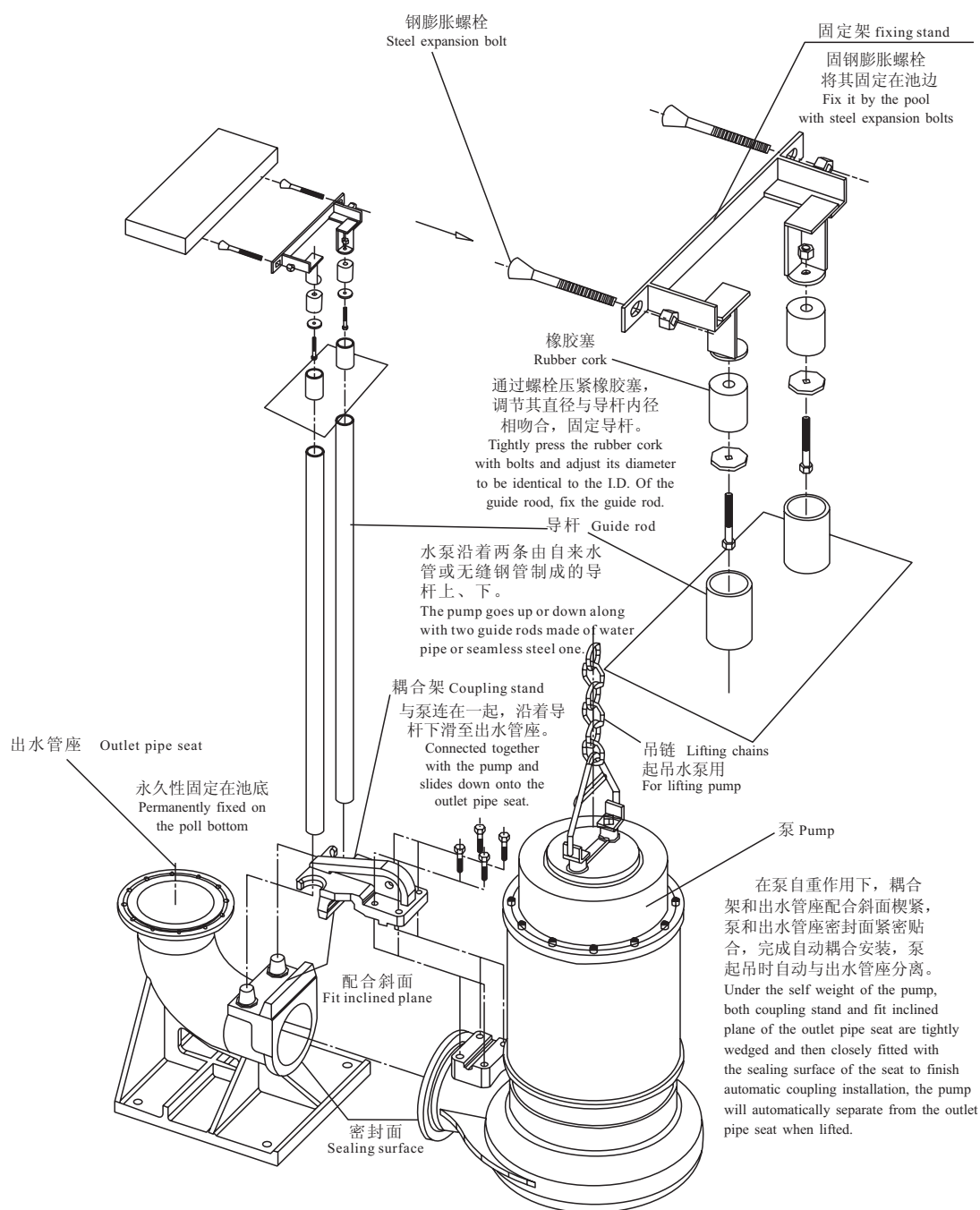

## WQ型泵安装方式 WQ type pump installation method

### 2、移动式硬管安装

泵由其底座支承，硬管接头与管路系统连接。

### 3、移动式软管安装

泵由其底座支承，软管接头与出水胶管相接，多用途，易于安装，水泵可轻易地从一个污水井移到另一个污水井。

### 2.Movable Hard Pipe Installtion

The pump is supported by its foundation, the hard pipe joint is connected to the pipeline system.

### 3.Movable Soft Pipe Installation

The pump is supported by its foundation, the soft pipe joint is connected to the outlet rubber pipe, of multiple purposes, easy to be mounted, the pump can be easily moved from one sewage well to another.

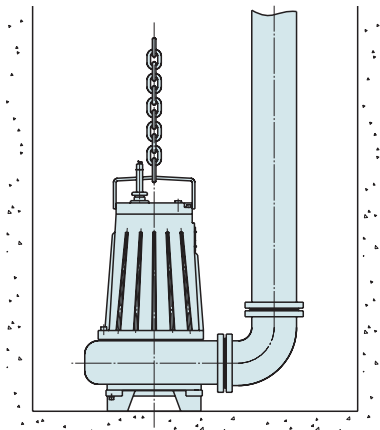

移动式硬管安装  
Movable Hard Pipe Installation

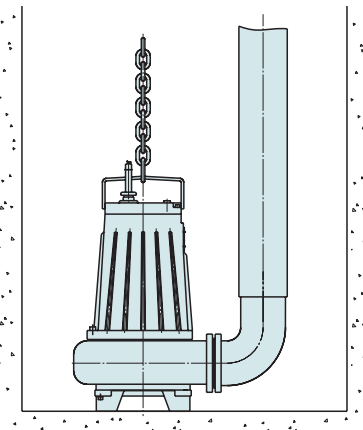

移动式软管安装  
Movable Soft Pipe Installation

### 4、固定式干式安装

能经受水淹，供湿/干井或管线连接的泵系统。吸水口和排水口以法兰与管道联接，立式安装。选用此种安装，须配冷却系统。

### 5、固定式湿式安装

泵由底座支承，固定于污水井底，排水口与管道连接，立式安装。

### 4.Fixed Dry Installation

For those pump system able to be subjected to water flood and for connecting to wet/dry well or pipeline.

### 5.Fixed Wet Installation

The pump is supported by its foundation and fixed on the bottom of a sewage well with the outlet connected to the pipeline, vertically mounted.

WQ型泵安装方式 WQ type pump installation method

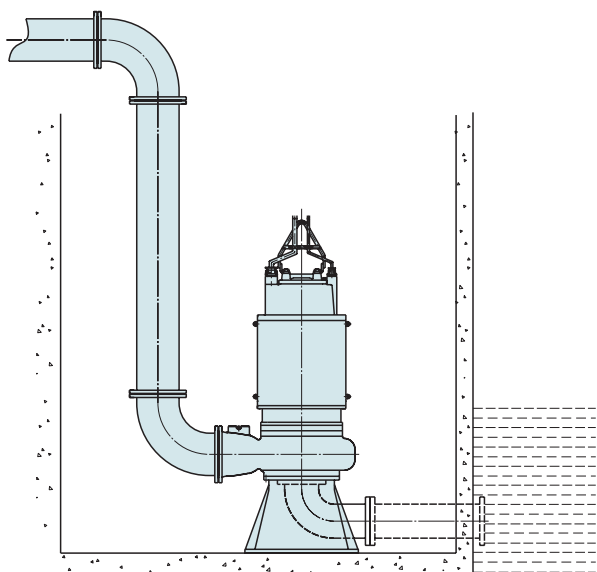

固定式干式安装  
Fixed Dry Installation

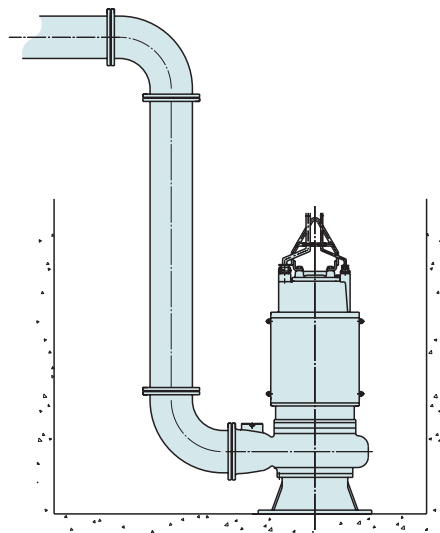

固定式湿式安装  
Fixed Wet Installation

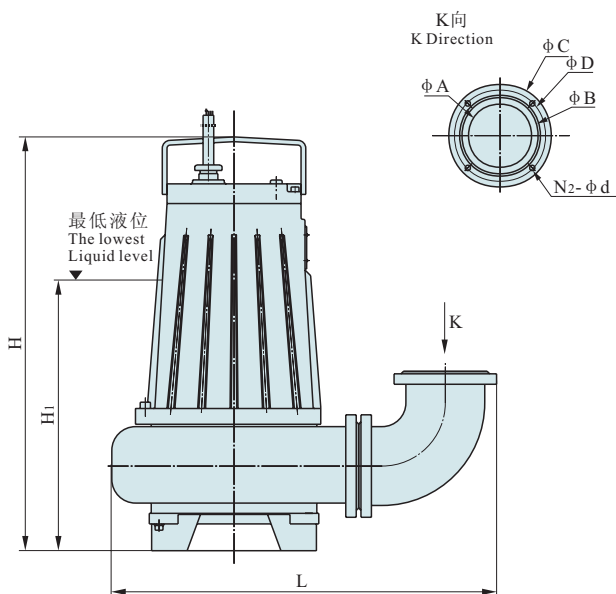

硬管联接尺寸  
Hard pipe connection dimension

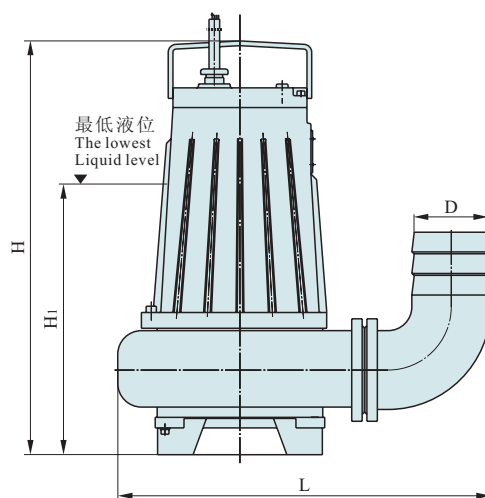

软管联接尺寸  
Soft pipe connection dimension

WQ型泵安装尺寸表 WQ type pump dimension table

序号 No.	型号 Type	硬管联接尺寸 Hard pipe connection dimension								软管联接尺寸 Soft pipe connection dimension			
		φA	φB	φC	φD	N2-φd	H	H <sub>1</sub>	L	φD	L	H	H <sub>1</sub>
1	50WQ15-8-0.75	50	90	140	110	4-φ13.5	575	380	495	60	460	575	380
2	50WQ15-12-1.1	50	90	140	110	4-φ13.5	575	380	495	60	460	575	380
3	50WQ15-16-1.5	50	90	140	110	4-φ13.5	605	385	495	60	460	605	385
4	50WQ15-22-2.2	50	90	140	110	4-φ13.5	605	385	495	60	460	605	385
5	50WQ15-30-3	50	90	140	110	4-φ13.5	665	420	520	60	485	665	420
6	50WQ25-25-4	50	90	140	110	4-φ13.5	675	515	520	60	485	675	515
7	50WQ25-32-5.5	50	90	140	110	4-φ13.5	760	515	650	60	615	760	515
8	50WQ25-36-7.5	50	90	140	110	4-φ13.5	760	515	650	60	615	760	515
9	65WQ30-10-2.2	65	110	160	130	4-φ13.5	685	460	610	74	550	685	460
10	65WQ30-15-3	65	110	160	130	4-φ13.5	685	460	610	74	550	685	460
11	65WQ30-22-4	65	110	160	130	4-φ13.5	695	465	680	74	620	695	465
12	65WQ30-30-5.5	65	110	160	130	4-φ13.5	760	515	680	74	620	760	515
13	65WQ30-35-7.5	65	110	160	130	4-φ13.5	760	515	680	74	620	760	515
14	80WQ50-8-2.2	80	128	190	150	4-φ17.5	755	470	700	86	600	755	470
15	80WQ50-10-3	80	128	190	150	4-φ17.5	755	470	700	86	600	755	470
16	80WQ50-15-4	80	128	190	150	4-φ17.5	765	470	700	86	600	765	470
17	80WQ50-20-5.5	80	128	190	150	4-φ17.5	830	515	740	86	640	830	515
18	80WQ50-25-7.5	80	128	190	150	4-φ17.5	830	515	740	86	640	830	515
19	100WQ80-7-3	100	148	210	170	4-φ17.5	755	515	720	100	618	755	515
20	100WQ80-10-4	100	148	210	170	4-φ17.5	765	515	720	100	618	765	515
21	100WQ80-13-5.5	100	148	210	170	4-φ17.5	830	565	770	100	668	830	565
22	100WQ80-18-7.5	100	148	210	170	4-φ17.5	830	565	770	100	668	830	565
23	150WQ150-7-5.5	150	202	265	225	8-φ17.5	885	550	910	150	853	885	550
24	150WQ150-10-7.5	150	202	265	225	8-φ17.5	885	550	910	150	853	885	550

WQ型泵自动耦合安装尺寸表 WQ type pump auto-coupled installation dimensions table

序号 No.	型 号 Type	φ A	φ B	φ C	φ D	N <sub>2</sub> - φ d	H	H <sub>1</sub>	H <sub>2</sub>	H <sub>3</sub>	H <sub>4</sub>	h	G	J	S	T	g	f	p	y	o	N <sub>1</sub> - φ d
1	50WQ15-8-0.75	50	90	140	110	4- φ 13.5	495	215	50	—	430	20	65	105	55	315	260	310	230	210	—	4- φ 20
2	50WQ15-12-1.1	50	90	140	110	4- φ 13.5	495	215	50	—	430	20	65	105	55	315	260	310	230	210	—	4- φ 20
3	50WQ15-16-1.5	50	90	140	110	4- φ 13.5	525	215	50	—	430	20	65	105	55	315	260	310	230	210	—	4- φ 20
4	50WQ15-22-2.2	50	90	140	110	4- φ 13.5	525	215	50	—	430	20	65	105	55	315	260	310	230	210	—	4- φ 20
5	50WQ15-30-3	50	90	140	110	4- φ 13.5	585	215	50	—	490	20	65	105	55	340	260	310	230	210	—	4- φ 20
6	50WQ25-25-4	50	90	140	110	4- φ 13.5	595	215	50	—	530	20	65	105	55	340	260	310	230	210	—	4- φ 20
7	50WQ25-32-5.5	50	90	140	110	4- φ 13.5	680	215	50	—	555	20	65	105	55	395	260	310	230	210	—	4- φ 20
8	50WQ25-36-7.5	50	90	140	110	4- φ 13.5	680	215	50	—	555	20	65	105	55	395	260	310	230	210	—	4- φ 20
9	65WQ30-10-2.2	65	110	160	130	4- φ 13.5	605	240	65	—	545	20	80	120	55	365	275	310	250	225	—	4- φ 20
10	65WQ30-15-3	65	110	160	130	4- φ 13.5	605	240	65	—	545	20	80	120	55	365	275	310	250	225	—	4- φ 20
11	65WQ30-22-4	65	110	160	130	4- φ 13.5	615	240	65	—	565	20	80	120	55	395	275	310	250	225	—	4- φ 20
12	65WQ30-30-5.5	65	110	160	130	4- φ 13.5	680	240	65	—	615	20	80	120	55	395	275	310	250	225	—	4- φ 20
13	65WQ30-35-7.5	65	110	160	130	4- φ 13.5	680	240	65	—	615	20	80	120	55	395	275	310	250	225	—	4- φ 20
14	80WQ50-8-2.2	80	128	190	150	4- φ 17.5	635	275	80	—	595	25	70	175	90	455	290	340	255	260	—	4- φ 20
15	80WQ50-10-3	80	128	190	150	4- φ 17.5	635	275	80	—	595	25	70	175	90	455	290	340	255	260	—	4- φ 20
16	80WQ50-15-4	80	128	190	150	4- φ 17.5	645	275	80	—	615	25	70	175	90	455	290	340	255	260	—	4- φ 20
17	80WQ50-20-5.5	80	128	190	150	4- φ 17.5	710	275	80	—	660	25	70	175	90	475	290	340	255	260	—	4- φ 20
18	80WQ50-25-7.5	80	128	190	150	4- φ 17.5	710	275	80	—	660	25	70	175	90	475	290	340	255	260	—	4- φ 20
19	80WQ50-35-11	80	128	190	150	4- φ 17.5	915	275	80	—	790	25	70	175	90	455	290	340	255	260	—	4- φ 20
20	80WQ50-40-15	80	128	190	150	4- φ 17.5	915	275	80	—	790	25	70	175	90	455	290	340	255	260	—	4- φ 20
21	100WQ80-7-3	100	148	210	170	4- φ 17.5	635	330	100	—	650	25	90	215	90	465	340	410	305	310	—	4- φ 20
22	100WQ80-10-4	100	148	210	170	4- φ 17.5	645	330	100	—	650	25	90	215	90	465	340	410	305	310	—	4- φ 20
23	100WQ80-13-5.5	100	148	210	170	4- φ 17.5	710	330	100	—	690	25	90	215	90	505	340	410	305	310	—	4- φ 20
24	100WQ80-18-7.5	100	148	210	170	4- φ 17.5	710	330	100	—	690	25	90	215	90	505	340	410	305	310	—	4- φ 20
25	100WQ80-24-11	100	148	210	170	4- φ 17.5	915	330	100	—	825	25	90	215	90	485	340	410	305	310	—	4- φ 20
26	100WQ80-32-15	100	148	210	170	4- φ 17.5	915	330	100	—	825	25	90	215	90	485	340	410	305	310	—	4- φ 20
27	100WQ80-36-18.5	100	148	210	170	4- φ 17.5	915	330	100	—	825	25	90	215	90	485	340	410	305	310	—	4- φ 20

WQ SERIES SUBMERSIBLE SEWAGE PUMP

WQ型泵自动耦合安装尺寸表 WQ type pump auto-coupled installation dimensions table

P	Q	K	L	M	e	n	m	E
98	108	420	260	210	30	18	40	700 570
98	108	420	260	210	30	18	40	700 570
98	108	420	260	210	30	18	40	700 570
98	108	420	260	210	30	18	40	700 570
118	127	465	260	210	30	18	40	850 700
118	127	465	260	210	30	18	40	850 700
195	210	500	260	210	30	18	40	850 700
195	210	500	260	210	30	18	40	850 700
152	173	527	260	210	30	18	40	850 700
152	173	527	260	210	30	18	40	850 700
194	210	596	260	210	30	18	40	900 750
194	210	596	260	210	30	18	40	900 750
194	210	596	260	210	30	18	40	900 750
163	190	630	380	320	30	18	40	850 700
163	190	630	380	320	30	18	40	850 700
163	190	630	380	320	30	18	40	850 700
185	205	670	380	320	30	18	40	900 750
185	205	670	380	320	30	18	40	900 750
163	180	625	380	320	30	18	40	900 750
163	180	625	380	320	30	18	40	900 750
169	202	650	380	320	30	18	40	950 750
169	202	650	380	320	30	18	40	950 750
180	207	700	380	320	30	18	40	950 750
180	207	700	380	320	30	18	40	950 750
163	186	655	380	320	30	18	40	950 750
163	186	655	380	320	30	18	40	950 750
163	186	655	380	320	30	18	40	1000 700

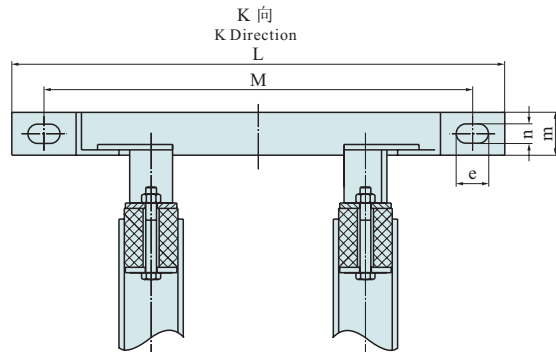
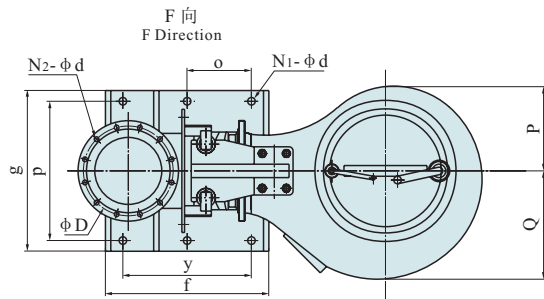
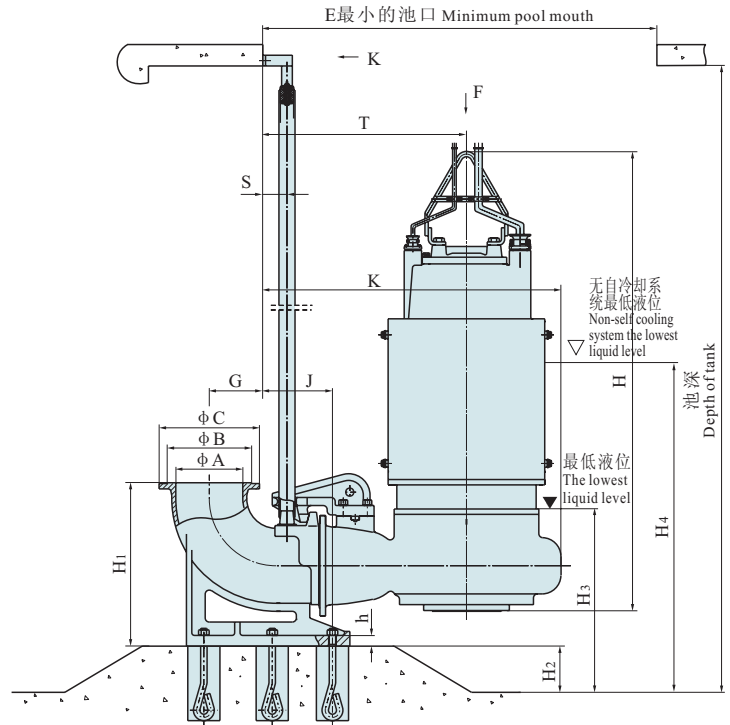

WQ型泵自动耦合安装尺寸表 WQ type pump auto-coupled installation dimensions table

序号 No.	型 号 Type	φ A	φ B	φ C	φ D	N <sub>2</sub> - φ d	H	H <sub>1</sub>	H <sub>2</sub>	H <sub>3</sub>	H <sub>4</sub>	h	G	J	S	T	g	f	p	y	o	N <sub>1</sub> - φ d
28	100WQ80-40-22	100	148	210	170	4- φ 17.5	960	330	100	—	825	25	90	215	90	485	340	410	305	310	—	4- φ 20
29	150WQ150-7-5.5	150	202	265	225	8- φ 17.5	765	485	150	—	845	35	125	260	90	545	480	500	440	400	—	4- φ 20
30	150WQ150-10-7.5	150	202	265	225	8- φ 17.5	765	485	150	—	845	35	125	260	90	545	480	500	440	400	—	4- φ 20
31	150WQ150-15-11	150	202	265	225	8- φ 17.5	1005	485	150	—	985	35	125	260	90	545	480	500	440	400	—	4- φ 20
32	150WQ150-20-15	150	202	265	225	8- φ 17.5	1005	485	150	—	985	35	125	260	90	545	480	500	440	400	—	4- φ 20
33	150WQ150-25-18.5	150	202	265	225	8- φ 17.5	1085	485	150	—	1035	35	125	260	90	595	480	500	440	400	—	4- φ 20
34	150WQ150-30-22	150	202	265	225	8- φ 17.5	1085	485	150	—	1035	35	125	260	90	595	480	500	440	400	—	4- φ 20
35	150WQ150-40-30	150	202	265	225	8- φ 17.5	1495	485	150	530	1155	35	125	260	90	595	480	500	440	400	—	4- φ 20
36	150WQ150-45-37	150	202	265	225	8- φ 17.5	1605	485	150	530	1175	35	125	260	90	645	480	500	440	400	—	4- φ 20
37	150WQ150-50-45	150	202	265	225	8- φ 17.5	1605	485	150	530	1175	35	125	260	90	645	480	500	440	400	—	4- φ 20
38	150WQ100-60-55	150	202	265	225	8- φ 17.5	1605	485	150	530	1175	35	125	260	90	645	480	500	440	400	—	4- φ 20
39	200WQ300-7-11	200	260	320	280	8- φ 17.5	1020	570	200	—	1050	30	200	260	90	600	550	610	500	470	—	4- φ 30
40	200WQ300-10-15	200	260	320	280	8- φ 17.5	1020	570	200	—	1050	30	200	260	90	600	550	610	500	470	—	4- φ 30
41	200WQ300-13-18.5	200	260	320	280	8- φ 17.5	1085	570	200	—	1120	30	200	260	90	600	550	610	500	470	—	4- φ 30
42	200WQ300-15-22	200	260	320	280	8- φ 17.5	1085	570	200	—	1120	30	200	260	90	600	550	610	500	470	—	4- φ 30
43	200WQ300-20-30	200	260	320	280	8- φ 17.5	1650	570	200	670	1300	30	200	260	90	700	550	610	500	470	—	4- φ 30
44	200WQ300-25-37	200	260	320	280	8- φ 17.5	1650	570	200	670	1300	30	200	260	90	700	550	610	500	470	—	4- φ 30
45	200WQ400-27-45	200	260	320	280	8- φ 17.5	1685	570	200	670	1300	30	200	260	90	700	550	610	500	470	—	4- φ 30
46	200WQ400-34-55	200	260	320	280	8- φ 17.5	1685	570	200	670	1300	30	200	260	90	700	550	610	500	470	—	4- φ 30
47	200WQ400-40-75	200	260	320	280	8- φ 17.5	1805	570	250	670	1420	30	200	260	90	700	550	610	500	470	—	4- φ 30
48	200WQ400-48-90	200	260	320	280	8- φ 17.5	1805	570	250	670	1420	30	200	260	90	700	550	610	500	470	—	4- φ 30
49	250WQ400-7-15	250	312	375	335	12- φ 17.5	1045	610	250	—	1150	40	200	260	90	630	600	610	520	480	—	4- φ 30
50	250WQ400-10-18.5	250	312	375	335	12- φ 17.5	1085	610	250	—	1200	40	200	260	90	630	600	610	520	480	—	4- φ 30
51	250WQ400-13-22	250	312	375	335	12- φ 17.5	1085	610	250	—	1200	40	200	260	90	630	600	610	520	480	—	4- φ 30
52	250WQ500-10-30	250	312	375	335	12- φ 17.5	1650	610	250	740	1380	40	200	260	90	760	600	610	520	480	—	4- φ 30
53	250WQ500-16-37	250	312	375	335	12- φ 17.5	1650	610	250	740	1380	40	200	260	90	760	600	610	520	480	—	4- φ 30
54	250WQ500-20-45	250	312	375	335	12- φ 17.5	1735	610	250	740	1430	40	200	260	90	760	600	610	520	480	—	4- φ 30

WQ型泵自动耦合安装尺寸表 WQ type pump auto-coupled installation dimensions table

P	Q	K	L	M	e	n	m	E	
163	186	655	380	320	30	18	40	1000	700
203	250	772	380	320	30	18	40	950	750
203	250	772	380	320	30	18	40	950	750
203	250	772	380	320	30	18	40	950	750
203	250	772	380	320	30	18	40	950	750
233	262	840	380	320	30	18	40	1100	800
233	262	840	380	320	30	18	40	1100	800
233	262	840	380	320	30	18	40	1300	1000
288	316	945	380	320	30	18	40	1300	1000
288	316	945	380	320	30	18	40	1400	1100
288	316	945	380	320	30	18	40	1400	1100
239	318	878	460	400	30	18	40	1000	700
239	318	878	460	400	30	18	40	1000	700
239	318	878	460	400	30	18	40	1150	900
239	318	878	460	400	30	18	40	1150	900
309	376	1042	460	400	30	18	40	1300	1000
309	376	1042	460	400	30	18	40	1300	1000
309	376	1042	460	400	30	18	40	1300	1000
309	376	1042	460	400	30	18	40	1300	1000
309	376	1042	460	400	30	18	40	1400	1100
309	376	1042	460	400	30	18	40	1400	1100
253	333	923	460	400	30	18	40	1150	900
253	333	923	460	400	30	18	40	1150	900
253	333	923	460	400	30	18	40	1150	900
319	404	1098	460	400	30	18	40	1300	1000
319	404	1098	460	400	30	18	40	1300	1000
319	404	1098	460	400	30	18	40	1300	1000

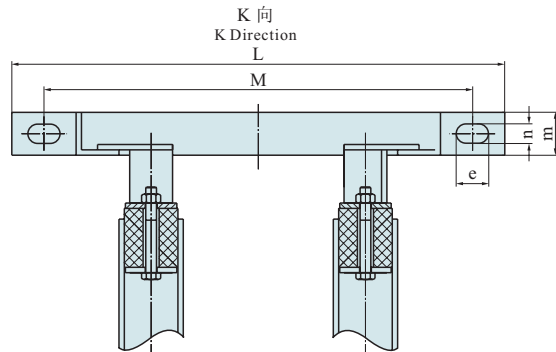
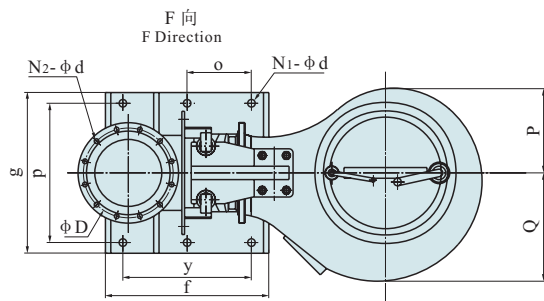
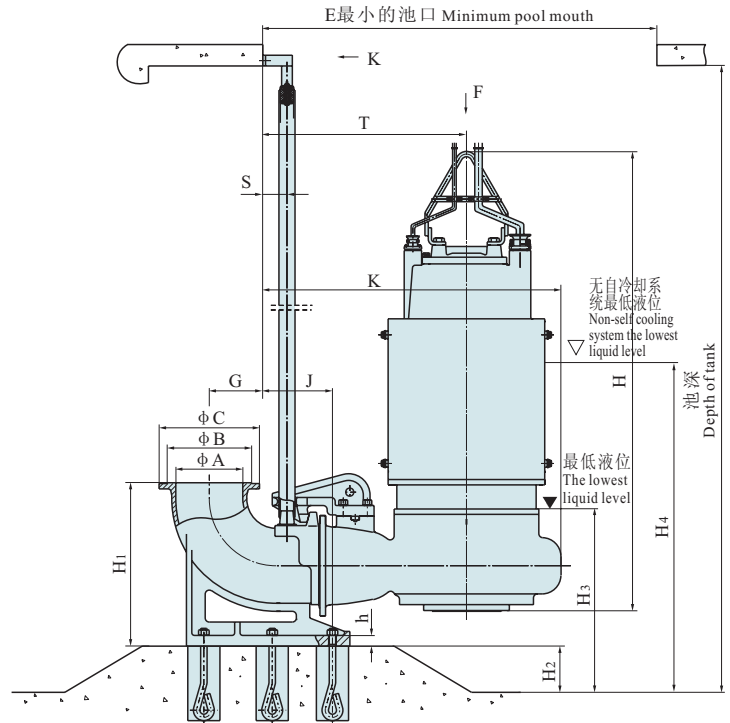

WQ型泵自动耦合安装尺寸表 WQ type pump auto-coupled installation dimensions table

序号 No.	型 号 Type	φ A	φ B	φ C	φ D	N2- φ d	H	H <sub>1</sub>	H <sub>2</sub>	H <sub>3</sub>	H <sub>4</sub>	h	G	J	S	T	g	f	p	y	o	N1- φ d
55	250WQ500-25-55	250	312	375	335	12-φ 17.5	1735	610	250	740	1430	40	200	260	90	760	600	610	520	480	—	4-φ 30
56	250WQ600-28-75	250	312	375	335	12-φ 17.5	1805	610	250	740	1430	40	200	260	90	760	600	610	520	480	—	4-φ 30
57	250WQ600-34-90	250	312	375	335	12-φ 17.5	1805	610	250	740	1430	40	200	260	90	760	600	610	520	480	—	4-φ 30
58	250WQ600-40-110	250	312	375	335	12-φ 17.5	2020	610	250	740	1650	40	200	260	90	760	600	610	520	480	—	4-φ 30
59	250WQ600-50-132	250	312	375	335	12-φ 17.5	2020	610	250	740	1650	40	200	260	90	760	600	610	520	480	—	4-φ 30
60	300WQ600-6-18.5	300	365	440	395	12-φ 22	1115	720	250	—	1320	45	250	330	90	700	880	870	780	770	—	4-φ 30
61	300WQ600-7-22	300	365	440	395	12-φ 22	1115	720	250	—	1320	45	250	330	90	700	880	870	780	770	—	4-φ 30
62	300WQ700-11-30	300	365	440	395	12-φ 22	1680	720	300	840	1500	45	250	330	90	770	880	870	780	770	—	4-φ 30
63	300WQ700-14-37	300	365	440	395	12-φ 22	1680	720	300	840	1500	45	250	330	90	770	880	870	780	770	—	4-φ 30
64	300WQ700-16-45	300	365	440	395	12-φ 22	1765	720	300	840	1550	45	250	330	90	770	880	870	780	770	—	4-φ 30
65	300WQ700-19-55	300	365	440	395	12-φ 22	1765	720	300	840	1550	45	250	330	90	770	880	870	780	770	—	4-φ 30
66	300WQ1000-20-75	300	365	440	395	12-φ 22	2045	720	300	840	1760	45	250	330	90	920	880	870	780	770	—	4-φ 30
67	300WQ1000-24-90	300	365	440	395	12-φ 22	2045	720	300	840	1760	45	250	330	90	920	880	870	780	770	—	4-φ 30
68	300WQ1000-28-110	300	365	440	395	12-φ 22	2050	720	300	840	1790	45	250	330	90	770	880	870	780	770	—	4-φ 30
69	300WQ1000-35-132	300	365	440	395	12-φ 22	2050	720	300	840	1790	45	250	330	90	770	880	870	780	770	—	4-φ 30
70	350WQ1200-6-30	350	415	490	445	12-φ 22	1745	820	350	1000	1610	45	335	315	125	915	880	870	780	770	—	4-φ 30
71	350WQ1200-8-37	350	415	490	445	12-φ 22	1830	820	350	1000	1670	45	335	315	125	915	880	870	780	770	—	4-φ 30
72	350WQ1100-10-45	350	415	490	445	12-φ 22	1830	820	350	1000	1670	45	335	315	125	915	880	870	780	770	—	4-φ 30
73	350WQ1100-12-55	350	415	490	445	12-φ 22	2115	820	350	1000	1900	45	335	315	125	915	880	870	780	770	—	4-φ 30
74	350WQ1100-16-75	350	415	490	445	12-φ 22	2045	820	350	1000	1900	45	335	315	125	965	880	870	780	770	—	4-φ 30
75	350WQ1100-20-90	350	415	490	445	12-φ 22	2045	820	350	1000	1900	45	335	315	125	965	880	870	780	770	—	4-φ 30
76	350WQ1100-25-110	350	415	490	445	12-φ 22	2350	820	350	1000	1900	45	335	315	125	965	880	870	780	770	—	4-φ 30
77	350WQ1100-30-132	350	415	490	445	12-φ 22	2350	820	350	1000	1900	45	335	315	125	965	880	870	780	770	—	4-φ 30
78	350WQ1100-36-160	350	415	490	445	12-φ 22	2350	820	350	1000	1900	45	335	315	125	965	880	870	780	770	—	4-φ 30
79	350WQ1500-30-185	350	415	490	445	12-φ 22	2350	820	350	1000	1900	45	335	315	125	965	880	870	780	770	—	4-φ 30
80	350WQ1500-32-200	350	415	490	445	12-φ 22	2660	820	350	1000	1990	45	335	315	125	1115	880	870	780	770	—	4-φ 30
81	350WQ1500-35-220	350	415	490	445	12-φ 22	2660	820	350	1000	1990	45	335	315	125	1115	880	870	780	770	—	4-φ 30

WQ型泵自动耦合安装尺寸表 WQ type pump auto-coupled installation dimensions table

P	Q	K	L	M	e	n	m	E	
319	404	1098	460	400	30	18	40	1300	1000
319	404	1098	460	400	30	18	40	1300	1000
319	404	1098	460	400	30	18	40	1300	1000
319	404	1098	460	400	30	18	40	1300	1000
319	404	1098	460	400	30	18	40	1300	1000
300	400	1050	460	400	30	18	40	1150	950
300	400	1050	460	400	30	18	40	1150	950
349	473	1178	460	400	30	18	40	1400	1100
349	473	1178	460	400	30	18	40	1400	1100
349	473	1178	460	400	30	18	40	1400	1100
349	473	1178	460	400	30	18	40	1400	1100
349	473	1178	460	400	30	18	40	1400	1100
375	488	1351	460	400	30	18	40	1600	1300
375	488	1351	460	400	30	18	40	1600	1300
349	473	1178	460	400	30	18	40	1600	1300
349	473	1178	460	400	30	18	40	1600	1300
363	499	1346	640	580	30	18	60	1600	1300
363	499	1346	640	580	30	18	60	1600	1300
363	499	1346	640	580	30	18	60	1600	1300
363	499	1346	640	580	30	18	60	1600	1300
375	488	1396	640	580	30	18	60	1700	1400
375	488	1396	640	580	30	18	60	1700	1400
388	523	1422	640	580	30	18	60	1700	1400
388	523	1422	640	580	30	18	60	1700	1400
388	523	1422	640	580	30	18	60	1900	1500
547	645	1715	640	580	30	18	60	1600	1300
547	645	1715	640	580	30	18	60	1600	1300
547	645	1715	640	580	30	18	60	1600	1300

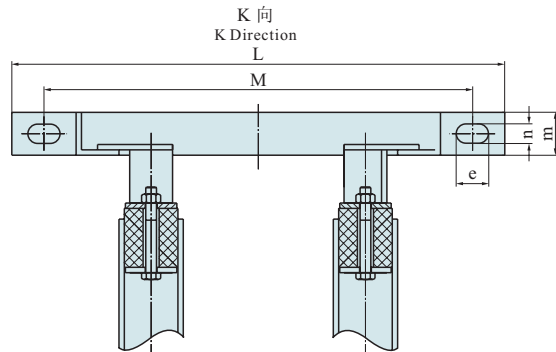
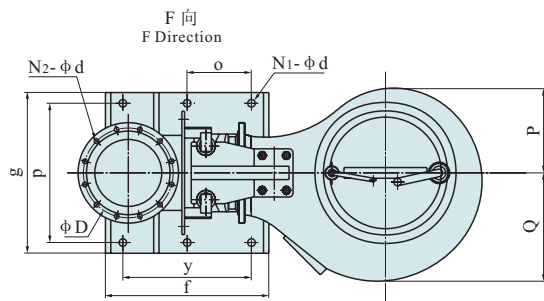
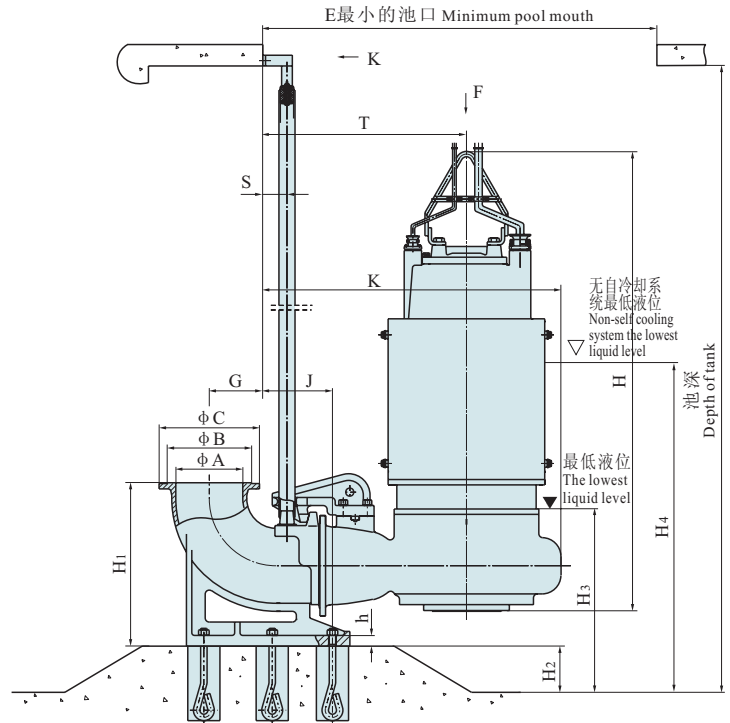

WQ型泵自动耦合安装尺寸表 WQ type pump auto-coupled installation dimensions table

序号 No.	型 号 Type	φ A	φ B	φ C	φ D	N2- φ d	H	H1	H2	H3	H4	h	G	J	S	T	g	f	p	y	o	N1- φ d
82	350WQ1500-40-250	350	415	490	445	12- φ 22	2885	820	350	1000	2215	45	335	315	125	1115	880	870	780	770	—	4- φ 30
83	350WQ1800-40-280	350	415	490	445	12- φ 22	2885	820	350	1000	2215	45	335	315	125	1115	880	870	780	770	—	4- φ 30
84	350WQ1800-43-315	350	415	490	445	12- φ 22	2885	820	350	900	2215	45	335	315	125	1115	880	870	780	770	—	4- φ 30
85	350WQ1800-46-355	350	415	490	445	12- φ 22	2885	820	350	900	2215	45	335	315	125	1115	880	870	780	770	—	4- φ 30
86	400WQ1500-5-30	400	482	565	515	16- φ 26	1745	940	400	1100	1730	50	480	370	125	965	880	950	780	850	425	6- φ 40
87	400WQ1500-6-37	400	482	565	515	16- φ 26	1830	940	400	1100	1730	50	480	370	125	965	880	950	780	850	425	6- φ 40
88	400WQ1500-8-45	400	482	565	515	16- φ 26	1830	940	400	1100	1730	50	480	370	125	965	880	950	780	850	425	6- φ 40
89	400WQ1500-10-55	400	482	565	515	16- φ 26	2115	940	400	1100	1880	50	480	370	125	965	880	950	780	850	425	6- φ 40
90	400WQ1500-12-75	400	482	565	515	16- φ 26	2115	940	400	1100	1880	50	480	370	125	965	880	950	780	850	425	6- φ 40
91	400WQ1500-15-90	400	482	565	515	16- φ 26	2115	940	400	1100	1880	50	480	370	125	965	880	950	780	850	425	6- φ 40
92	400WQ1500-18-110	400	482	565	515	16- φ 26	2115	940	400	1100	1880	50	480	370	125	965	880	950	780	850	425	6- φ 40
93	400WQ1500-22-132	400	482	565	515	16- φ 26	2395	940	400	1100	1880	50	480	370	125	965	880	950	780	850	425	6- φ 40
94	400WQ2000-20-160	400	482	565	515	16- φ 26	2395	940	400	1100	1880	50	480	370	125	965	880	950	780	850	425	6- φ 40
95	400WQ2000-23-185	400	482	565	515	16- φ 26	2395	940	400	1100	1880	50	480	370	125	965	880	950	780	850	425	6- φ 40
96	400WQ2000-25-200	400	482	565	515	16- φ 26	2660	940	400	1100	1990	50	480	370	125	1115	880	950	780	850	425	6- φ 40
97	400WQ2000-28-220	400	482	565	515	16- φ 26	2660	940	400	1100	1990	50	480	370	125	1115	880	950	780	850	425	6- φ 40
98	400WQ2000-32-250	400	482	565	515	16- φ 26	2885	940	400	1100	2210	50	480	370	125	1115	880	950	780	850	425	6- φ 40
99	400WQ2000-36-280	400	482	565	515	16- φ 26	2885	940	400	1100	2210	50	480	370	125	1115	880	950	780	850	425	6- φ 40
100	400WQ2000-40-315	400	482	565	515	16- φ 26	2885	940	400	1100	2210	50	480	370	125	1115	880	950	780	850	425	6- φ 40
101	400WQ2000-45-355	400	482	565	515	16- φ 26	2885	940	400	1100	2210	50	480	370	125	1115	880	950	780	850	425	6- φ 40
102	500WQ2000-7-55	500	585	670	620	20- φ 26	2115	1120	500	1300	2060	55	510	355	125	1040	1210	1300	1090	1180	590	6- φ 50
103	500WQ2200-8-75	500	585	670	620	20- φ 26	2115	1120	500	1300	2060	55	510	355	125	1040	1210	1300	1090	1180	590	6- φ 50
104	500WQ2200-10-90	500	585	670	620	20- φ 26	2115	1120	500	1300	2060	55	510	355	125	1040	1210	1300	1090	1180	590	6- φ 50
105	500WQ2200-12-110	500	585	670	620	20- φ 26	2115	1120	500	1300	2060	55	510	355	125	1040	1210	1300	1090	1180	590	6- φ 50
106	500WQ2200-15-132	500	585	670	620	20- φ 26	2115	1120	500	1300	2200	55	510	355	125	1340	1210	1300	1090	1180	590	6- φ 50
107	500WQ3000-11-132	500	585	670	620	20- φ 26	2815	1120	500	1300	2200	55	510	355	125	1340	1210	1300	1090	1180	590	6- φ 50
108	500WQ3000-13-160	500	585	670	620	20- φ 26	2815	1120	500	1300	2200	55	510	355	125	1340	1210	1300	1090	1180	590	6- φ 50

WQ SERIES SUBMERSIBLE SEWAGE PUMP

WQ型泵自动耦合安装尺寸表 WQ type pump auto-coupled installation dimensions table

P	Q	K	L	M	e	n	m	E	
547	645	1715	640	580	30	18	60	1600	1300
547	645	1715	640	580	30	18	60	1600	1300
547	645	1715	640	580	30	18	60	1600	1300
547	645	1715	640	580	30	18	60	1600	1300
377	533	1375	640	580	30	18	60	1600	1300
377	533	1375	640	580	30	18	60	1600	1300
377	533	1375	640	580	30	18	60	1600	1300
377	533	1375	640	580	30	18	60	1600	1300
367	507	1355	640	580	30	18	60	1700	1400
367	507	1355	640	580	30	18	60	1700	1400
367	507	1355	640	580	30	18	60	1700	1400
367	507	1355	640	580	30	18	60	1700	1400
475	615	1611	640	580	30	18	60	1900	1500
475	615	1611	640	580	30	18	60	1900	1500
475	615	1611	640	580	30	18	60	1900	1500
535	690	1786	640	580	30	18	60	1900	1500
535	690	1786	640	580	30	18	60	1900	1500
535	690	1786	640	580	30	18	60	1900	1500
535	690	1786	640	580	30	18	60	1900	1500
535	690	1786	640	580	30	18	60	1900	1500
535	690	1786	640	580	30	18	60	1900	1500
575	815	2000	640	580	30	18	60	1900	1600
575	815	2000	640	580	30	18	60	1900	1600
575	815	2000	640	580	30	18	60	1900	1600
575	815	2000	640	580	30	18	60	1900	1600
575	815	2000	640	580	30	18	60	1900	1600
575	815	2000	640	580	30	18	60	1900	1600
575	815	2000	640	580	30	18	60	1900	1600

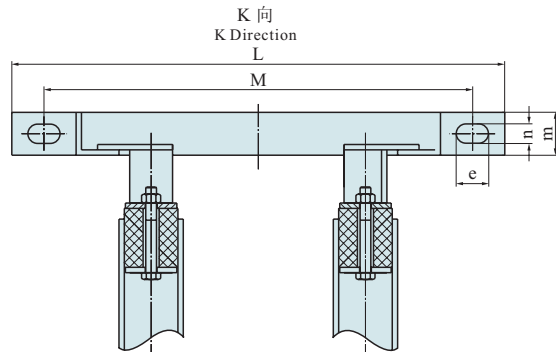
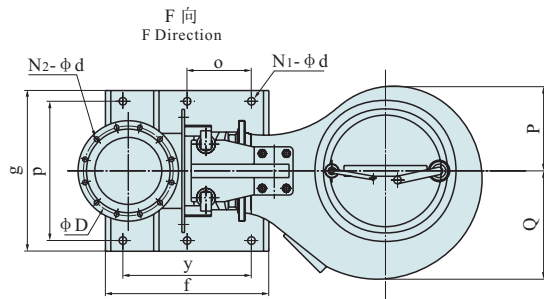
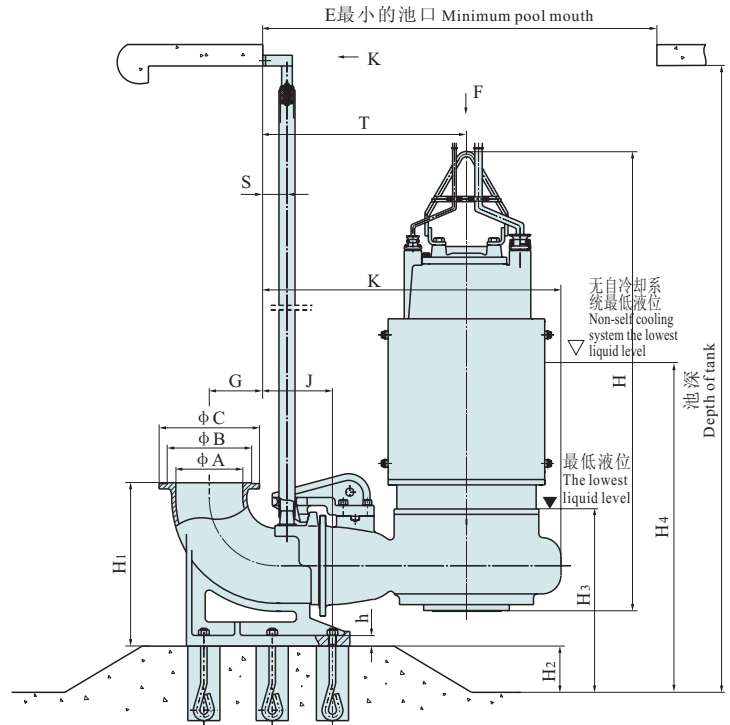

WQ型泵自动耦合安装尺寸表 WQ type pump auto-coupled installation dimensions table

序号 No.	型 号 Type	φ A	φ B	φ C	φ D	N2-φ d	H	H1	H2	H3	H4	h	G	J	S	T	g	f	p	y	o	N1-φ d
109	500WQ3000-15-185	500	585	670	620	20-φ 26	2815	1120	500	1300	2200	55	510	355	125	1340	1210	1300	1090	1180	590	6-φ 50
110	500WQ3000-16-200	500	585	670	620	20-φ 26	2815	1120	500	1300	2200	55	510	355	125	1340	1210	1300	1090	1180	590	6-φ 50
111	500WQ3000-18-220	500	585	670	620	20-φ 26	2815	1120	500	1300	2200	55	510	355	125	1340	1210	1300	1090	1180	590	6-φ 50
112	500WQ3000-21-250	500	585	670	620	20-φ 26	3040	1120	500	1300	2200	55	510	355	125	1340	1210	1300	1090	1180	590	6-φ 50
113	500WQ3000-24-280	500	585	670	620	20-φ 26	3040	1120	500	1300	2200	55	510	355	125	1340	1210	1300	1090	1180	590	6-φ 50
114	600WQ3000-8-110	600	685	780	725	20-φ 30	2815	1280	600	1530	2400	55	540	475	125	1320	1210	1300	1090	1180	590	6-φ 50
115	600WQ3000-10-132	600	685	780	725	20-φ 30	2815	1280	600	1530	2400	55	540	475	125	1320	1210	1300	1090	1180	590	6-φ 50
116	600WQ4000-10-160	600	685	780	725	20-φ 30	2815	1280	600	1530	2400	55	540	475	125	1320	1210	1300	1090	1180	590	6-φ 50
117	600WQ4000-11-185	600	685	780	725	20-φ 30	2815	1280	600	1530	2400	55	540	475	125	1320	1210	1300	1090	1180	590	6-φ 50
118	600WQ4000-12-200	600	685	780	725	20-φ 30	2815	1280	600	1530	2400	55	540	475	125	1320	1210	1300	1090	1180	590	6-φ 50
119	600WQ4000-14-220	600	685	780	725	20-φ 30	2815	1280	600	1530	2400	55	540	475	125	1320	1210	1300	1090	1180	590	6-φ 50
120	600WQ4000-16-250	600	685	780	725	20-φ 30	3040	1280	600	1530	2625	55	540	475	125	1320	1210	1300	1090	1180	590	6-φ 50
121	600WQ4000-18-280	600	685	780	725	20-φ 30	3040	1280	600	1530	2625	55	540	475	125	1320	1210	1300	1090	1180	590	6-φ 50
122	600WQ4000-20-315	600	685	780	725	20-φ 30	3040	1280	600	1530	2625	55	540	475	125	1320	1210	1300	1090	1180	590	6-φ 50

潜水排污泵导轨长度与池深关系一览表 Lead rail length and pool depth table

口径 dia	导杆规格 leader type	导轨长度 lead rail length	口径 dia	导杆规格 leader type	导轨长度 lead rail length
50	1'	池深 pool depth -230mm	100	2'	池深 pool depth -410mm
65	1'	池深 pool depth -265mm	150	2'	池深 pool depth -530mm
80	2'	池深 pool depth -310mm	200	2'	池深 pool depth -610mm

WQ SERIES SUBMERSIBLE SEWAGE PUMP

WQ型泵自动耦合安装尺寸表 WQ type pump auto-coupled installation dimensions table

P	Q	K	L	M	e	n	m	E	
575	815	2000	640	580	30	18	60	1900	1600
575	815	2000	640	580	30	18	60	1900	1600
555	740	1940	640	580	30	18	60	2100	1800
555	740	1940	640	580	30	18	60	2100	1800
555	740	1940	640	580	30	18	60	2100	1800
575	815	2000	640	580	30	18	60	2200	1900
575	815	2000	640	580	30	18	60	2200	1900
575	815	2000	640	580	30	18	60	2200	1900
575	815	2000	640	580	30	18	60	2200	1900
575	815	2000	640	580	30	18	60	2200	1900
552	802	1902	640	580	30	18	60	2200	1900
552	802	1902	640	580	30	18	60	2200	1900
552	802	1902	640	580	30	18	60	2200	1900
552	802	1902	640	580	30	18	60	2200	1900

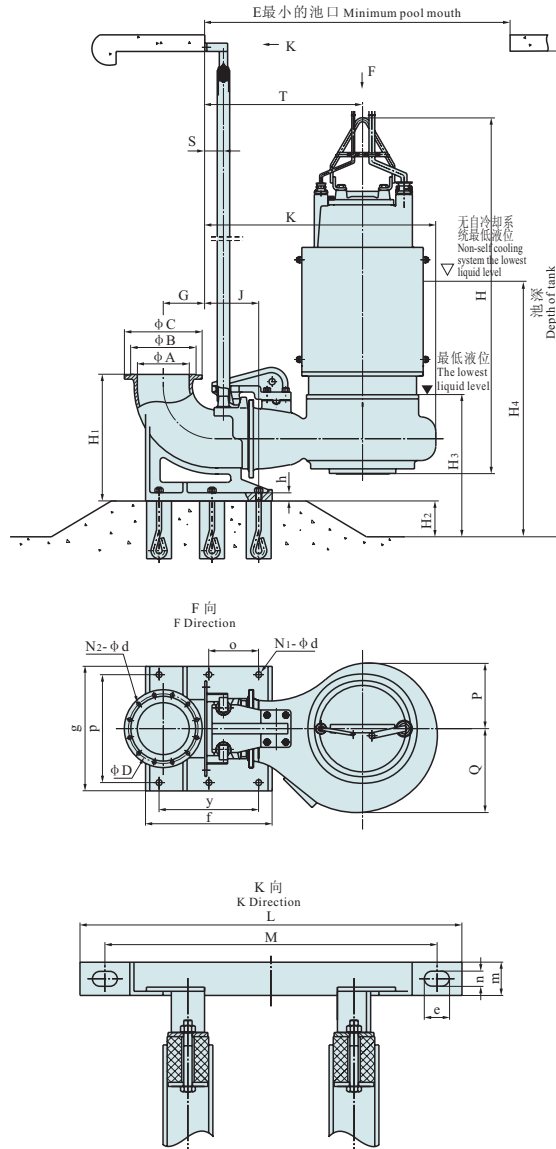

潜水排污泵导轨长度与池深关系一览表 Lead rail length and pool depth table

口径 dia	导杆规格 leader type	导轨长度 lead rail length	口径 dia	导杆规格 leader type	导轨长度 lead rail length
250	2'	池深 pool depth -730mm	400	3'	池深 pool depth -1160mm
300	2'	池深 pool depth -890mm	500	3'	池深 pool depth -1390mm
350	3'	池深 pool depth -1020mm	600	3'	池深 pool depth -1610mm

WQ型泵固定式安装尺寸表 WQ type pump fixed installation dimensions table

序号 No.	型号 Type	外型尺寸 (Figure dimension)												
		φA	φB	φC	φD	N <sub>2</sub> -φd	H	O	P	Q	L	E E	F F	N <sub>1</sub> -φk
1	80WQ50-35-11	80	128	190	150	4-φ17.5	830	212	163	180	280	520 520	600 600	4-φ25
2	80WQ50-40-15	80	128	190	150	4-φ17.5	830	212	163	180	280	520 520	600 600	4-φ25
3	100WQ80-24-11	100	148	210	170	4-φ17.5	830	205	163	180	280	520 520	600 600	4-φ25
4	100WQ80-32-15	100	148	210	170	4-φ17.5	830	205	163	180	280	520 520	600 600	4-φ25
5	100WQ80-36-18.5	100	148	210	170	4-φ17.5	830	256	163	180	280	520 520	600 600	4-φ25
6	100WQ80-40-22	100	148	210	170	4-φ17.5	875	256	163	180	280	520 520	600 600	4-φ25
7	150WQ150-15-11	150	202	265	225	8-φ17.5	870	228	203	250	350	520 520	600 600	4-φ25
8	150WQ150-20-15	150	202	265	225	8-φ17.5	870	228	203	250	350	520 520	600 600	4-φ25
9	150WQ150-25-18.5	150	202	265	225	8-φ17.5	935	247	233	262	400	565 565	640 640	4-φ25
10	150WQ150-30-22	150	202	265	225	8-φ17.5	935	247	233	262	400	565 565	640 640	4-φ25
11	150WQ150-40-30	150	202	265	225	8-φ17.5	1345	367	233	262	400	800 800	900 900	4-φ40
12	150WQ150-45-37	150	202	265	225	8-φ17.5	1450	367	288	316	450	800 800	900 900	4-φ40
13	150WQ150-50-45	150	202	265	225	8-φ17.5	1450	367	288	316	450	800 800	900 900	4-φ40
14	150WQ100-60-55	150	202	265	225	8-φ17.5	1450	367	288	316	450	800 800	900 900	4-φ40
15	200WQ300-7-11	200	260	320	280	8-φ17.5	870	254	212	295	400	520 520	600 600	4-φ25
16	200WQ300-10-15	200	260	320	280	8-φ17.5	870	254	212	295	400	520 520	600 600	4-φ25
17	200WQ300-13-18.5	200	260	320	280	8-φ17.5	930	267	230	300	400	520 520	600 600	4-φ25
18	200WQ300-15-22	200	260	320	280	8-φ17.5	930	267	230	300	400	520 520	600 600	4-φ25
19	200WQ300-20-30	200	260	320	280	8-φ17.5	1480	342	309	376	500	700 700	800 800	4-φ40
20	200WQ300-25-37	200	260	320	280	8-φ17.5	1480	342	309	376	500	700 700	800 800	4-φ40
21	200WQ400-27-45	200	260	320	280	8-φ17.5	1515	349	332	368	500	800 800	900 900	4-φ40
22	200WQ400-34-55	200	260	320	280	8-φ17.5	1515	349	332	368	500	800 800	900 900	4-φ40
23	200WQ400-40-75	200	260	320	280	8-φ17.5	1635	379	362	398	500	800 800	900 900	4-φ40
24	200WQ400-48-90	200	260	320	280	8-φ17.5	1635	379	362	398	500	800 800	900 900	4-φ40
25	250WQ400-7-15	250	312	375	335	12-φ17.5	910	254	212	295	420	520 520	600 600	4-φ25

WQ型泵固定式安装尺寸表 WQ type pump fixed installation dimensions table

湿式安装 Wet installation			干式安装 Dry installation			
H1	H4	H5	L1	H2	H3	H4
300	—	860	—	—	—	—
300	—	860	—	—	—	—
300	—	860	—	—	—	—
300	—	860	—	—	—	—
300	—	875	—	—	—	—
300	—	875	—	—	—	—
320	—	905	—	—	—	—
320	—	905	—	—	—	—
320	—	955	—	—	—	—
320	—	955	—	—	—	—
480	620	1175	500	410	200	750
480	620	1175	500	410	200	750
480	620	1175	500	410	200	750
480	620	1175	500	410	200	750
330	—	850	—	—	—	—
330	—	850	—	—	—	—
330	—	850	—	—	—	—
445	640	1130	450	420	250	870
445	640	1130	450	420	250	870
495	660	1180	500	475	250	890
495	660	1180	500	475	250	890
495	660	1230	500	475	250	890
495	660	1230	500	475	250	890
330	—	950	—	—	—	—

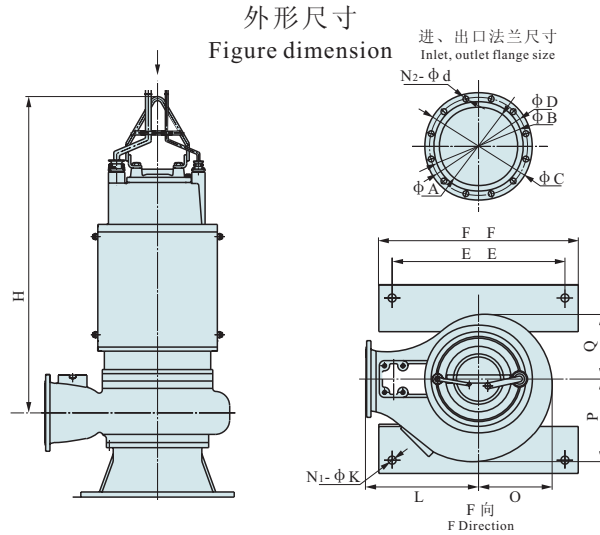

固定式湿式安装  
Fixed wet installation

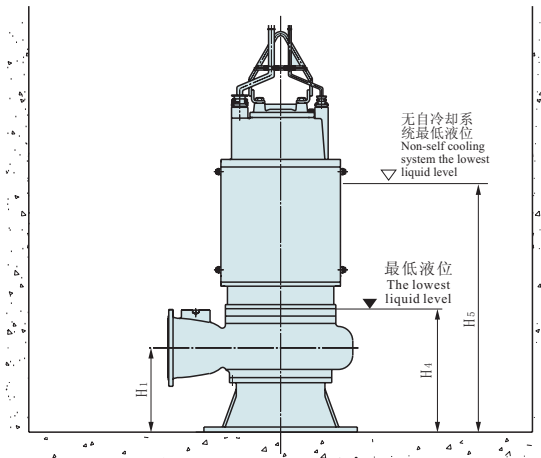

固定式干式安装  
Fixed dry installation

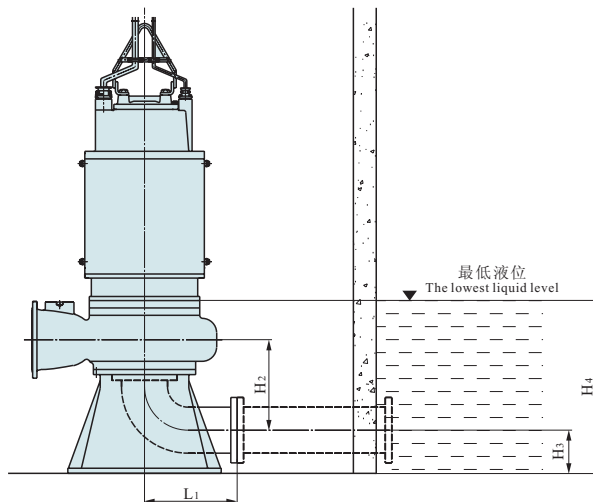

WQ型泵固定式安装尺寸表 WQ type pump fixed installation dimensions table

序号 No.	型号 Type	外型尺寸 (Figure dimension)													
		φA	φB	φC	φD	N <sub>2</sub> -φd	H	O	P	Q	L	E E	F F	N <sub>1</sub> -φk	
26	250WQ400-10-18.5	250	312	375	335	12-φ17.5	950	267	230	300	420	520 520	600 600	4-φ25	
27	250WQ400-13-22	250	312	375	335	12-φ17.5	950	267	230	300	420	520 520	600 600	4-φ25	
28	250WQ500-10-30	250	312	375	335	12-φ17.5	1480	360	319	404	550	700 700	800 800	4-φ40	
29	250WQ500-16-37	250	312	375	335	12-φ17.5	1480	360	319	404	550	700 700	800 800	4-φ40	
30	250WQ500-20-45	250	312	375	335	12-φ17.5	1565	360	319	404	550	700 700	800 800	4-φ40	
31	250WQ500-25-55	250	312	375	335	12-φ17.5	1565	360	319	404	550	700 700	800 800	4-φ40	
32	250WQ600-28-75	250	312	375	335	12-φ17.5	1635	379	362	398	550	800 800	900 900	4-φ40	
33	250WQ600-34-90	250	312	375	335	12-φ17.5	1635	379	362	398	550	800 800	900 900	4-φ40	
34	250WQ600-40-110	250	312	375	335	12-φ17.5	1850	379	362	398	550	800 800	900 900	4-φ40	
35	250WQ600-50-132	250	312	375	335	12-φ17.5	1850	379	362	398	550	800 800	900 900	4-φ40	
36	300WQ600-6-18.5	300	365	440	395	12-φ22	970	267	230	300	400	520 520	600 600	4-φ25	
37	300WQ600-7-22	300	365	440	395	12-φ22	970	267	230	300	400	520 520	600 600	4-φ25	
38	300WQ700-11-30	300	365	440	395	12-φ22	1485	378	327	430	550	700 700	800 800	4-φ40	
39	300WQ700-14-37	300	365	440	395	12-φ22	1485	378	327	430	550	700 700	800 800	4-φ40	
40	300WQ700-16-45	300	365	440	395	12-φ22	1570	397	344	454	550	700 700	800 800	4-φ40	
41	300WQ700-19-55	300	365	440	395	12-φ22	1570	397	344	454	550	700 700	800 800	4-φ40	
42	300WQ1000-20-75	300	365	440	395	12-φ22	1835	424	384	464	700	1000 1000	1100 1100	4-φ50	
43	300WQ1000-24-90	300	365	440	395	12-φ22	1835	424	384	464	700	1000 1000	1100 1100	4-φ50	
44	300WQ1000-28-110	300	365	440	395	12-φ22	1855	424	384	464	550	1000 1000	1100 1100	4-φ50	
45	300WQ1000-35-132	300	365	440	395	12-φ22	1855	424	384	464	550	1000 1000	1100 1100	4-φ50	
46	350WQ1200-6-30	350	415	490	445	12-φ22	1470	434	363	499	650	1000 1000	1100 1100	4-φ50	
47	350WQ1200-8-37	350	415	490	445	12-φ22	1555	434	363	499	650	1000 1000	1100 1100	4-φ50	
48	350WQ1100-10-45	350	415	490	445	12-φ22	1555	434	363	499	650	1000 1000	1100 1100	4-φ50	
49	350WQ1100-12-55	350	415	490	445	12-φ22	1840	434	363	499	650	1000 1000	1100 1100	4-φ50	
50	350WQ1100-16-75	350	415	490	445	12-φ22	1840	424	384	464	700	1000 1000	1100 1100	4-φ50	

WQ型泵固定式安装尺寸表 WQ type pump fixed installation dimensions table

湿式安装 Wet installation			干式安装 Dry installation			
H1	H4	H5	L1	H2	H3	H4
330	—	950	—	—	—	—
330	—	950	—	—	—	—
445	640	1280	450	445	300	945
445	640	1280	450	445	300	945
445	640	1280	450	445	300	945
445	640	1330	450	445	300	945
495	660	1330	500	500	300	965
495	660	1330	500	500	300	965
495	660	1330	500	500	300	965
495	660	1330	500	500	300	965
330	—	1020	—	—	—	—
330	—	1020	—	—	—	—
460	650	1350	450	510	400	1100
460	650	1350	450	510	400	1100
460	650	1350	450	510	400	1100
460	650	1350	450	510	400	1100
580	700	1500	600	510	400	1100
580	700	1500	600	510	400	1100
580	700	1500	600	510	400	1100
580	700	1500	600	510	400	1100
655	800	1510	600	625	450	1200
655	800	1510	600	625	450	1200
655	800	1510	600	625	450	1200
655	800	1740	600	625	450	1200
600	820	1740	600	580	450	1220

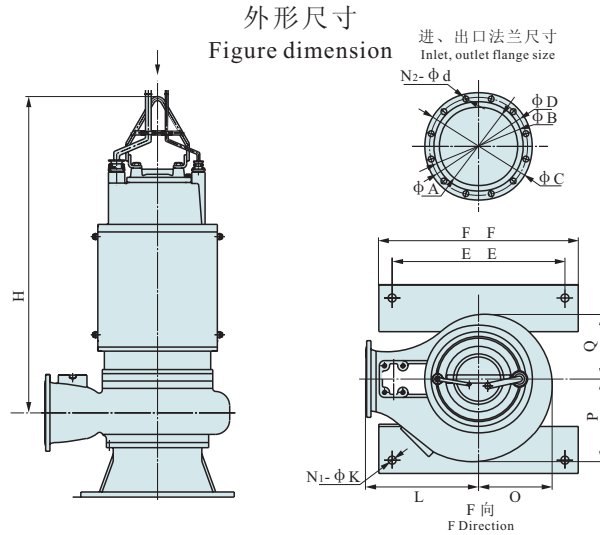

固定式湿式安装  
Fixed wet installation

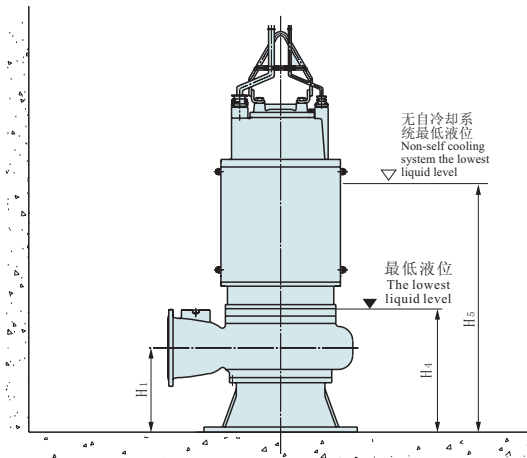

固定式干式安装  
Fixed dry installation

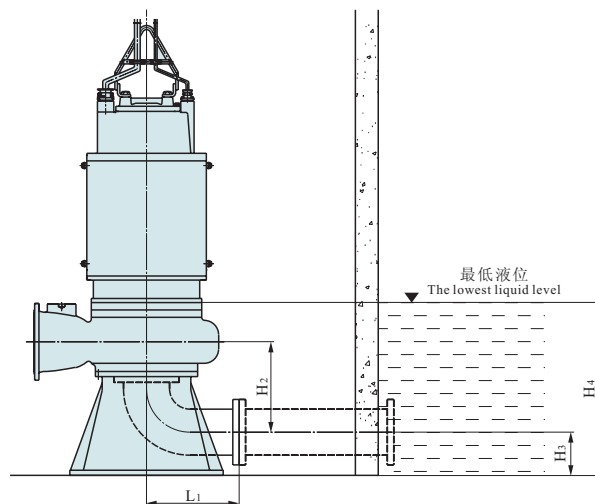

WQ型泵固定式安装尺寸表 WQ type pump fixed installation dimensions table

序号 No.	型号 Type	外型尺寸 (Figure dimension)														
		φA	φB	φC	φD	N <sub>2</sub> -φd	H	O	P	Q	L	E E	F F	N <sub>1</sub> -φk		
51	350WQ1100-20-90	350	415	490	445	12-φ22	1840	424	384	464	700	1000	1000	1100	1100	4-φ50
52	350WQ1100-25-110	350	415	490	445	12-φ22	1890	424	384	464	700	1000	1000	1100	1100	4-φ50
53	350WQ1100-30-132	350	415	490	445	12-φ22	1890	424	384	464	700	1000	1000	1100	1100	4-φ50
54	350WQ1100-36-160	350	415	490	445	12-φ22	1890	515	475	555	700	1000	1000	1100	1100	4-φ50
55	350WQ1500-30-185	350	415	490	445	12-φ22	1890	434	363	499	700	1000	1000	1100	1100	4-φ50
56	350WQ1500-32-200	350	415	490	445	12-φ22	2260	600	645	548	850	1000	1000	1100	1100	4-φ50
57	350WQ1500-35-220	350	415	490	445	12-φ22	2260	600	645	548	850	1000	1000	1100	1100	4-φ50
58	350WQ1500-40-250	350	415	490	445	12-φ22	2485	600	645	548	850	1000	1000	1100	1100	4-φ50
59	350WQ1800-40-280	350	415	490	445	12-φ22	2485	600	645	548	850	1000	1000	1100	1100	4-φ50
60	350WQ1800-43-315	350	415	490	445	12-φ22	2485	600	645	548	850	1000	1000	1100	1100	4-φ50
61	350WQ1800-46-355	350	415	490	445	12-φ22	2485	600	645	548	850	1000	1000	1100	1100	4-φ50
62	400WQ1500-5-30	400	482	565	515	16-φ26	1435	459	377	533	700	1000	1000	1100	1100	4-φ50
63	400WQ1500-6-37	400	482	565	515	16-φ26	1530	459	377	533	700	1000	1000	1100	1100	4-φ50
64	400WQ1500-8-45	400	482	565	515	16-φ26	1530	459	377	533	700	1000	1000	1100	1100	4-φ50
65	400WQ1500-10-55	400	482	565	515	16-φ26	1805	459	377	533	700	1000	1000	1100	1100	4-φ50
66	400WQ1500-12-75	400	482	565	515	16-φ26	1805	424	384	464	700	1000	1000	1100	1100	4-φ50
67	400WQ1500-15-90	400	482	565	515	16-φ26	1805	424	384	464	700	1000	1000	1100	1100	4-φ50
68	400WQ1500-18-110	400	482	565	515	16-φ26	1805	424	384	464	700	1000	1000	1100	1100	4-φ50
69	400WQ1500-22-132	400	482	565	515	16-φ26	1890	424	384	464	700	1000	1000	1100	1100	4-φ50
70	400WQ2000-20-160	400	482	565	515	16-φ26	1890	545	475	615	700	1000	1000	1100	1100	4-φ50
71	400WQ2000-23-185	400	482	565	515	16-φ26	1890	545	475	615	700	1000	1000	1100	1100	4-φ50
72	400WQ2000-25-200	400	482	565	515	16-φ26	2260	545	475	615	850	1100	1100	1200	1200	4-φ50
73	400WQ2000-28-220	400	482	565	515	16-φ26	2260	620	535	690	850	1100	1100	1200	1200	4-φ50
74	400WQ2000-32-250	400	482	565	515	16-φ26	2485	620	535	690	850	1100	1100	1200	1200	4-φ50
75	400WQ2000-36-280	400	482	565	515	16-φ26	2485	620	535	690	850	1100	1100	1200	1200	4-φ50

WQ型泵固定式安装尺寸表 WQ type pump fixed installation dimensions table

湿式安装 Wet installation			干式安装 Dry installation			
H1	H4	H5	L1	H2	H3	H4
600	820	1740	600	580	450	1220
600	820	1740	600	580	450	1220
600	820	1740	600	580	450	1220
600	820	1740	600	580	450	1220
655	800	1540	600	625	450	1200
655	800	1800	600	625	450	1200
655	800	1800	600	625	450	1200
655	800	2040	600	625	450	1200
655	800	2040	600	625	450	1200
655	800	2040	600	625	450	1200
655	800	2040	600	625	450	1200
690	800	1690	600	630	500	1300
690	800	1690	600	630	500	1330
690	800	1690	600	630	500	1330
690	800	1690	600	630	500	1330
690	820	1690	600	630	500	1330
690	820	1690	600	630	500	1330
690	820	1690	600	630	500	1330
690	850	1690	600	620	550	1400
690	850	1690	600	620	550	1400
710	850	1800	600	750	600	1750
710	950	1800	650	750	600	1750
710	950	2040	650	750	600	1750
710	950	2040	650	750	600	1750

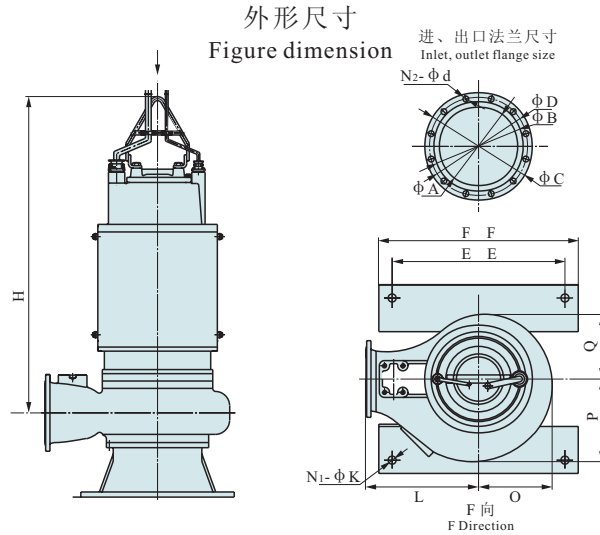

固定式湿式安装  
Fixed wet installation

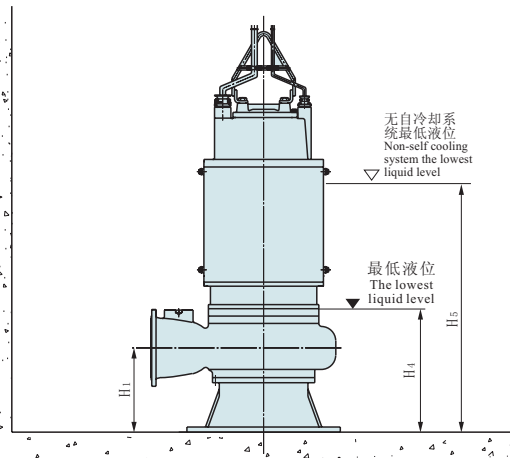

固定式干式安装  
Fixed dry installation

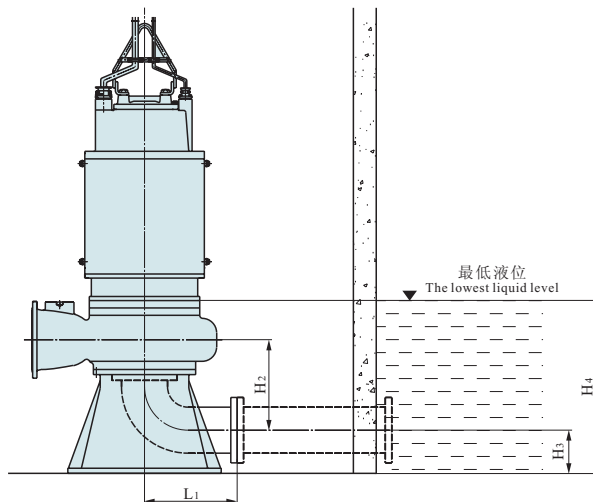

WQ型泵固定式安装尺寸表 WQ type pump fixed installation dimensions table

序号 No.	型号 Type	外型尺寸 (Figure dimension)													
		$\phi A$	$\phi B$	$\phi C$	$\phi D$	$N_2-\phi d$	H	O	P	Q	L	E E	F F	$N_1-\phi k$	
76	400WQ2000-40-315	400	482	565	515	16- $\phi 26$	2485	600	645	548	850	1100 1100	1200 1200	4- $\phi 50$	
77	400WQ2000-45-355	400	482	565	515	16- $\phi 26$	2485	600	645	548	850	1100 1100	1200 1200	4- $\phi 50$	
78	500WQ2000-7-55	500	585	670	620	20- $\phi 26$	1815	705	575	815	1000	1100 1100	1200 1200	4- $\phi 50$	
79	500WQ2200-8-75	500	585	670	620	20- $\phi 26$	1815	705	575	815	1000	1100 1100	1200 1200	4- $\phi 50$	
80	500WQ2200-10-90	500	585	670	620	20- $\phi 26$	2005	491	399	574	1000	1100 1100	1200 1200	4- $\phi 50$	
81	500WQ2200-12-110	500	585	670	620	20- $\phi 26$	2005	491	399	574	1000	1100 1100	1200 1200	4- $\phi 50$	
82	500WQ2200-15-132	500	585	670	620	20- $\phi 26$	2005	491	399	574	1000	1100 1100	1200 1200	4- $\phi 50$	
83	500WQ3000-11-132	500	585	670	620	20- $\phi 26$	2305	705	575	815	1000	1100 1100	1200 1200	4- $\phi 50$	
84	500WQ3000-13-160	500	585	670	620	20- $\phi 26$	2305	705	575	815	1000	1100 1100	1200 1200	4- $\phi 50$	
85	500WQ3000-15-185	500	585	670	620	20- $\phi 26$	2305	705	575	815	1000	1100 1100	1200 1200	4- $\phi 50$	
86	500WQ3000-16-200	500	585	670	620	20- $\phi 26$	2305	705	575	815	1000	1100 1100	1200 1200	4- $\phi 50$	
87	500WQ3000-18-220	500	585	670	620	20- $\phi 26$	2530	705	575	815	1000	1100 1100	1200 1200	4- $\phi 50$	
88	500WQ3000-21-250	500	585	670	620	20- $\phi 26$	2530	705	575	815	1000	1100 1100	1200 1200	4- $\phi 50$	
89	500WQ3000-24-280	500	585	670	620	20- $\phi 26$	2530	705	575	815	1000	1100 1100	1200 1200	4- $\phi 50$	
90	600WQ3000-8-110	600	685	780	725	20- $\phi 30$	2305	705	575	815	1000	1100 1100	1200 1200	4- $\phi 50$	
91	600WQ3000-10-132	600	685	780	725	20- $\phi 30$	2305	705	575	815	1000	1100 1100	1200 1200	4- $\phi 50$	
92	600WQ4000-10-160	600	685	780	725	20- $\phi 30$	2305	705	575	815	1000	1100 1100	1200 1200	4- $\phi 50$	
93	600WQ4000-11-185	600	685	780	725	20- $\phi 30$	2305	705	575	815	1000	1100 1100	1200 1200	4- $\phi 50$	
94	600WQ4000-12-200	600	685	780	725	20- $\phi 30$	2305	705	575	815	1000	1100 1100	1200 1200	4- $\phi 50$	
95	600WQ4000-14-220	600	685	780	725	20- $\phi 30$	2305	705	575	815	1000	1100 1100	1200 1200	4- $\phi 50$	
96	600WQ4000-16-250	600	685	780	725	20- $\phi 30$	2530	705	575	815	1000	1100 1100	1200 1200	4- $\phi 50$	
97	600WQ4000-18-280	600	685	780	725	20- $\phi 30$	2530	705	575	815	1000	1100 1100	1200 1200	4- $\phi 50$	
98	600WQ4000-20-315	600	685	780	725	20- $\phi 30$	2530	705	575	815	1000	1100 1100	1200 1200	4- $\phi 50$	

WQ型泵固定式安装尺寸表 WQ type pump fixed installation dimensions table

湿式安装 Wet installation			干式安装 Dry installation			
H1	H4	H5	L1	H2	H3	H4
710	800	2040	600	625	450	1200
710	800	2040	600	625	450	1200
780	1100	1790	650	850	750	1750
780	1100	1790	650	850	750	1750
780	950	1790	600	620	550	1750
780	950	1790	600	620	550	1750
780	950	1790	600	620	550	1750
780	950	1790	600	620	550	1750
780	1100	1930	650	750	600	1750
780	1100	1930	650	750	600	1750
780	1100	1930	650	750	600	1750
780	1100	1930	650	750	600	1750
780	1100	1930	650	750	600	1750
780	1100	1930	650	750	600	1750
780	1100	1930	650	750	600	1750
780	1100	1930	650	750	600	1750
780	1100	1930	650	750	600	1750
830	1200	1830	650	850	750	1900
830	1200	1830	650	850	750	1900
830	1200	1830	650	850	750	1900
830	1200	1905	650	850	750	1900
830	1200	1905	650	850	750	1900
830	1200	1905	650	850	750	1900
830	1200	1905	650	850	750	1900
830	1200	1905	650	850	750	1900
830	1200	1905	650	850	750	1900
830	1200	1905	650	850	750	1900
830	1200	1905	650	850	750	1900

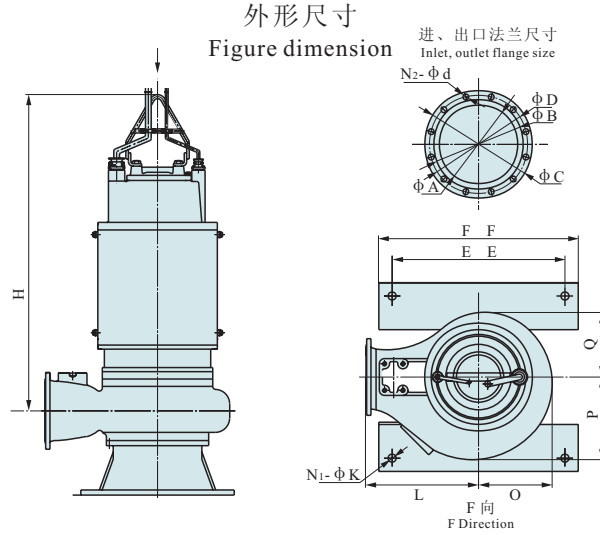

外形尺寸  
Figure dimension

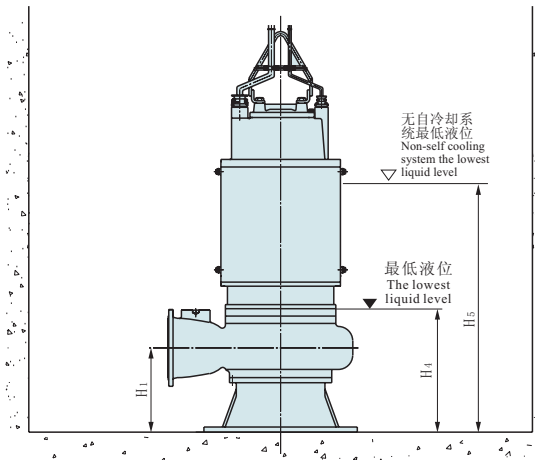

固定式湿式安装  
Fixed wet installation

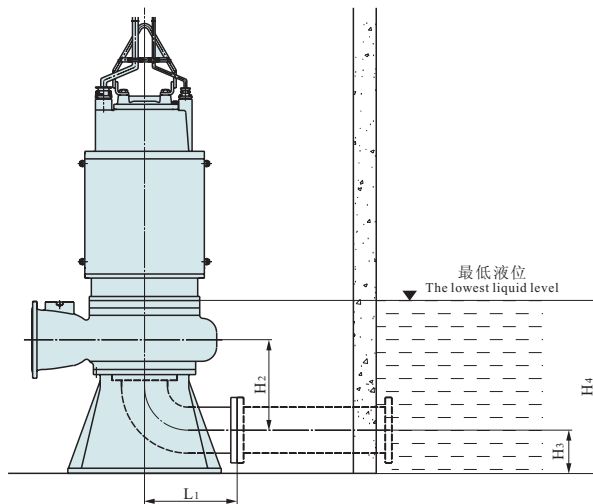

固定式干式安装  
Fixed dry installation

## 使用、检查与维修 Use, check and service

### 1、使用注意事项

泵不宜在易燃、易爆的介质环境中使用，也不宜抽送可燃性液体。

严禁撞击、压延电缆，严禁将电缆线当起吊绳使用。泵运行时不得随意拉电缆，以免损坏电缆发生触电事故或降低电缆密封性、降低电机接线腔绝缘性能。

当采用固定式自动耦合安装时，用吊链栓住提手上、下起吊泵，注意轻起轻放。

泵放入水中时应垂直起吊，不允许横放着地，更不能陷入污泥中。

吐出管路上应装流量调节阀，避免流量过大导致电机过载。

### 2、使用前的检查

仔细检查泵在运输、存放、安装过程中有无变形或损坏，紧固件是否松动或脱落。

检查电缆线有无破损、折断，电缆线的入口密封是否完好，发现有可能漏电及密封不良之处应及时妥善处理。

用500V兆欧表测量电机相间和相对地间的绝缘电阻，其值不应低于2兆欧，否则应对电机定子绕组进行干燥处理，干燥处理的温度不得超过120℃，或通生产厂家，以便提供帮助。

检查油室上的螺塞和密封垫片是否齐全。检查螺塞是否已将密封垫片压紧。

检查叶轮转动是否灵活。

检查电源装置是否安全可靠、正常、检查电缆中的接地线是否已可靠接地。

泵放入池之前须先进行点动检查转向是否正确，如转向不对，应立即切断电源，调换电控柜中接U、V、W的三相电缆中的任意两相。

### 1.Precautions at use

It is not proper to use the pump in a medium environment easy to explode and burn and to extract any combustible liquid.

It is strictly prohibited to impact or press the cable and use it as a lifting rope, and pull it at will when the pump is running so as not to damage it, which may result in an electric shock, or lowering the cable sealness, or the insulation performance of the wiring box of the motor.

When to use the way of fixed automatic coupling installation, lift or lower down the pump with the lifting chains locking the handle and take care to handle it.

The pump has to be vertically lifted when it is placed in water and not horizontally landed, further more, not sunk into sludge.

A flow regulating valve must be equipped with the spitting pipeline to avoid overload of the motor due to a too heavy flow.

### 2.Check before use

Carefully check if there is any deformation or damage with the pump and any looseness or fall-off with the fasteners during transport, storage and installation.

Check if any damage or fracture with the cable, if the seal on its inlet intact and make a proper treatment in time if any possible leakage or bad seal is found.

Measure the dielectric resistance between the phases and between the phase and ground with a 500V megohm 2 meter, the value of which has not to be lower than megohm, otherwise a drying treatment must be taken for the stator winding of the motor with a temperature not over 120℃ or notify the manufacturer for help.

Check if there is oil in the oil chamber and do not stop filling it until it overflows on the filler.

Check if the screw cork and sealing pad on the oil chamber are full and if the screw cork presses the sealing pad tightly.

Check if the impeller rotates flexibly.

Check if the power device safe, reliable or normal and if the grounding wire inside of the cable reliably grounded.

Before placing the pump in the pool, check if it is in a correct. Direction of rotation by way of dot moving and cut off the power and change the U, V, W three wires with any two of which in the electric control cabinet if not correct.

### 3、 起动

起动时应关闭吐出管路上的流量调节阀，当泵全速运转后再逐渐打开该阀门。注意不能长时间在该阀门关闭的情况下运转。

### 4、 停车

当泵停用预计达半月以上时，应将泵吊起清洗并置于干燥处。当气温较低时，应将泵提出水面并排尽泵内液体，防止冰冻。

### 5、 定期检查

电机相间和相对地间的绝缘电阻，其值不低于2兆欧，否则应拆机检修，同时应检查接地是否牢固可靠。

叶轮颈与泵体所装的密封环在直径方向的最大间隙过2mm时，应更换新的密封环。

泵在规定的工作介质条件下正常运行半年后，应检查油室状况，如油室中的油呈乳化状态，应及时更换N10机械油。如果换油运行很短时间漏水检测探头立即报警，可能泵侧机械密封已经损坏，应更换机械密封。对于在恶劣工作条件下使用的泵，更应经常检修。

在正常工作条件下泵工作一年后，应进行一次大修，更换已磨损的易损件并检查紧固件，同时应补充或更换轴润滑脂，保证泵在运行过程中的良好润滑。

需拆卸时不得猛敲猛打以免损坏密封件。非熟练技工不要随便拆卸泵以免造成泵泄露或电机损坏。

### 3.Starting

Close the flow regulating valve on the spitting pipeline at starting and gradually open it when the pump gets in the full speed running. Note the pump can not run for a long time with the valve closed.

### 4.Stopping

Lift the pump, clean it and place it in a dry place when intended not to use it up to half a month and lift it out of the water and let the liquid inside of it drain out to prevent it from being frozen when the temperature is very low.

### 5.Check

Periodically check the dielectric resistance between phases and between phase and ground, the value of which should not be lower than 2 megohm, otherwise it has to be removed to overhaul, and, at the same time, check if the grounding is secured and reliable.

Replace the seal ring with a new one when the max.interval of it, mounted on the impeller neck and pump casing,is over 2mm.

After half a year running of the pump under the provided working medium condition, check the state of the oil chamber and replace it with N10 mechanical oil if it shows emulsified state. It is possible that the mechanical seal on the pump. Side is made damaged when the leakage probe gives a warning with the pump running for a short time after the oil replacement and replace it at once. More often check the pump when it is used under a very adverse working condition.

After one year work of the pump under the normal working condition, a big overhaul must be taken for replacing the worn-out parts, checking the fasteners and supplementing or replacing the grease on the bearing so as to ensure a good lubrication of the pump during its running.

To disassemble, do not knock at it at will in order to avoid damaging the seal and do not allow non-skilled persons to do that in order not cause it leaking or the motor damaged.

## 故障原因及排除方法 Failures causes and troubleshooting

故障现象 Failure	可能产生的原因 Possible causes	排除方法 Troubleshooting
1、流量不足或不出 Flow not enough or not water out	a)叶轮反转 Impeller reversedly rotates b)流道堵塞 Geat blocked up c)被抽介质浓度过大 Too high concentration of the medium to be extracted d)装置扬程太高 Too high head e)叶轮严重磨损 Impeller seriously worn out	a)纠正电机转向 Correct its direction b)清除杂物 Get rid of foreign matters c)用水冲稀降低浓度 Get it thinned with water d)改泵或降低装置扬程 Change the pump or lower the head e)更换叶轮 Replace it
2、不能启动 Unable to start	a)缺相 Lack of phase b)叶轮卡住 Impeller blocked c)绕组接头或电缆断路 Circuit breaking of winding joint or cable d)定子绕组烧坏 Stator winding burnt e)电器控制故障 Electric control fault	a)检查线路 Check the circuit b)清除杂物 Get rid of foreign matters c)用欧姆表检查修复 Check and repair with an ohmmeter d)进行修理, 更换绕组 Repair or replace it e)检查控制柜, 修理后调换电器零件 Check electric control cabinet and replace faulty components
3、定子烧坏 Stator burnt	a)缺相运行 Running with phase lack b)被抽介质浓度过大 Too high concentration of the medium extracted c)叶轮卡死或松动 Impeller blocked or loose d)密封损坏电机进水 Seal damaged and water going in the motor e)紧固件松动造成电机进水 Fasteners loose to make water in the motor	修理好电机后, 使用前必须: After repair, it is required before use: a)查清线路, 清除故障 To check the circuit and clear off the failures b)用水稀释 Get it thinned with water c)清除脏物, 拧紧叶轮固螺钉 Get rid of dirt, tighten the screws on impeller d)更换机械密封或“O”型密封圈 Replace mechanical seal or "O"-ring seal e)拧紧各部紧固件 Tighten fasteners on every part
4、电流过大 Too heavy current	a)管道、叶轮被堵 Pipeline, impeller blocked up b)抽送液体的密度或粘度较高 Too high density or viscosity of the liquid extracted c)流量过大 Too heavy flow	a)清理管道和叶轮中的堵塞物 Clear up both b)改变抽送液体的密度或粘度 Change either of both c)关小出口阀, 减小流量 Close the outlet valve a little to reduce the flow

## 管路损耗参考表 Reference table for pipeline loss

管径 Pipe diameter (mm)	流量 Capacity(L/s)									
	1	2	4	6	8	10	15	20	25	30
25	32.7	13.0								
38	3.5	14	55							
50	0.8	3.1	13	29						
65		1.6	3.2	7.1	13	20				
75		0.4	0.8	3.3	5.9	9.6	21.6			
100			0.23	0.8	1.3	2.1	6.8	8.6	13	19.4
125				0.23	0.4	0.63	1.3	2.7	4.1	5.9
150					0.16	0.26	0.58	1.1	1.6	2.3
175						0.11	0.27	0.5	0.74	1.05
200							0.13	0.26	0.37	0.53
250								0.07	0.12	0.18
300										0.07

直管摩擦损失简表(估计用)100m直管损失米数以新铸铁管为标准,旧管加倍。  
Brief table for the frictional loss of a straight pipe(for evaluation),the lost meters of a 100m straight pipe takes the newly iron pipe as the standard and multiple for the old one.

### 阀及弯管折合直管长度(每个)

The length of a straight pipe converted into from both valve and elbow(each)

种类 Variety	折合直管直径倍数 Convert into the times of the diameter of a straight pipe	备注 Remark
标准弯头 Standard elbow	12	米级块弯头 Multiple in case of unopen
全开闸阀 Fully opened gate valve	25	
蝶阀 Back valve	100	
脚阀 Foot valve	100	部分堵塞弯头 Partial block-up multiplied

注: 例如100mm直管, 底阀折合100倍直径等于100 100=10000mm=10m直径长度, 假定流量为8L/s查上表, 直管每100m损失1.3m, 则10m损失0.13m, 即一个100mm底阀, 流量为8L/s时, 损失扬程0.13m。

Note: For instance, a 100mm diameter pipe, the foot valve has a 100 100=10000mm=10m diameter when which is converted into 100 times that of the pipe's diameter. Suppose the flow is 8L/s Looked into the above table, the loss of the straight pipe is 1.3m each 100m, then the one for 100mm is 0.13m, that is, for a 100mm foot valve with a flow 8L/s, its head loss is 0.13m.

### 一定管径直径之最大流量限制

Limit of the maximum flow for a pipe with a certain diameter

管径直径 Pipeline diameter (mm)	最大流量 Maximum flow (L/s)	最大流速 Maximum flow rate (m/s)	管径直径 Pipeline diameter (mm)	最大流量 Maximum flow (L/s)	最大流速 Maximum flow rate (m/s)
25	1	2.04	125	130.0	2.44
38	2.5	1.69	150	43.0	2.45
50	4.17	2.12	175	60.0	2.49
65	6.67	2.01	200	83.3	2.69
75	10.0	2.26	250	133.0	2.72
100	18.4	2.33	300	192.0	2.71

注: 超过此限使管路损失显著增加。

Note: The pipeline loss would be made greatly increased once the limit is over.