

Hannah Yan

Email:info@deponpump.cn

Mobile/Skype/WhatsApp:+86 151 0032 3669

Wechat:yhr20130801



*S Double suction
Water Pump*

S型泵简介

Brief introduction of S Type pump

产品概述General

- S型单级双吸离心泵是我公司在国内、外同行老型双吸泵的基础上新开发的新型节能卧式中开泵，供输送不含固体颗粒的清水或物理化学性质类似于水的其它液体，介质温度不超过80℃，该系列泵适用于工厂、矿山、城市给排水、电站、农田排灌及各种水利工程。

S type pump is a single-stage double-suction horizontal split centrifugal pump. It is used to transport pure water and the liquid which physical and chemical nature is similar with water, the maximum temperature isn't more than 80℃, this series of pump is suitable for water supply and drainage in factories, mines and cities, power station, drainage and irrigation of farming, and kinds of hydraulic projects.

产品特点Characteristic

- 结构紧凑、外形美观、运行平稳、噪声低；
Compact structure, beautiful outline, stable operation, low noise;
- 该系列泵的吸入口与排出口均在水泵轴心线的下方，检修时无需拆卸进出口管路及电机，只要将泵盖揭开即可将全部零件拆下进行维修；
Both inlet and outlet of this pump are placed under the axial line, so it is unnecessary to remove the inlet and outlet pipeline and motor;
- 水泵轴封有优质机械密封和软填料密封两种方式,可供用户在不同使用场合下选用；
The shaft seal of water pump has fine mechanical seal and soft stuffing seal, which can be selected according to different condition by user;
- 经过静平衡校验的叶轮,用圆螺母固定在泵轴上,其轴向位置可通过圆螺母进行调整；
The impeller is static-balance calibrated, fixed on the shaft with round nut, and its axial position can be adjusted via the round nut;
- 泵通过弹性联轴器由电动机直接传动,必要时也可用内燃机传动；
The pump is direct driven by motor via resilient coupling, it can be driven by internal combustion engine if it is necessary;
- 从传动方向看去,水泵为顺时针方向旋转(根据用户需要亦可改为逆时针方向旋转)；
The pump is clockwise viewing from driving end (It can be changed to anticlockwise according to users' need)

型号意义Model meaning

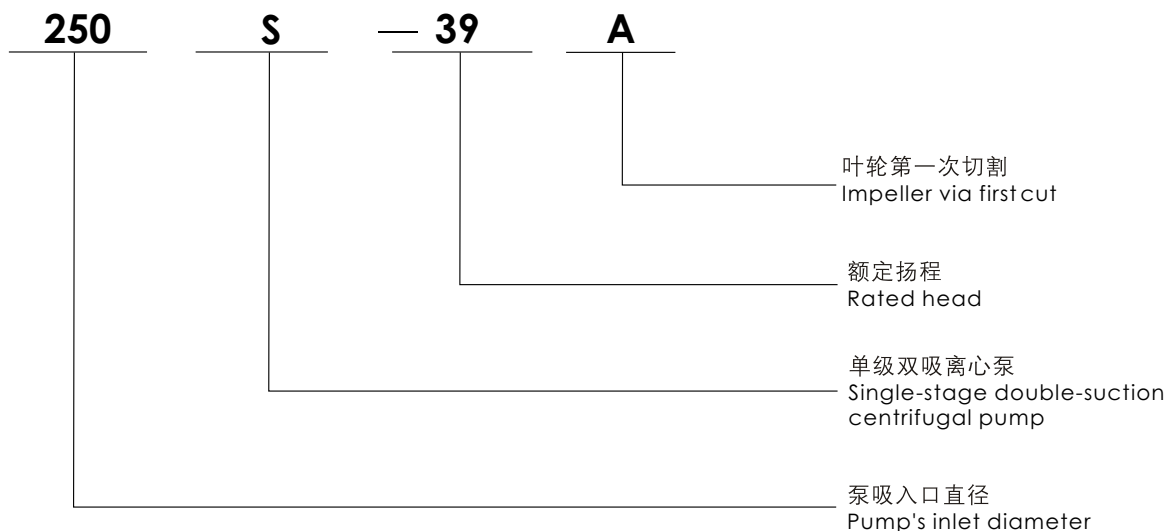

S型泵结构图

Structural drawing of S Type pump

■ 结构图 Structural drawing

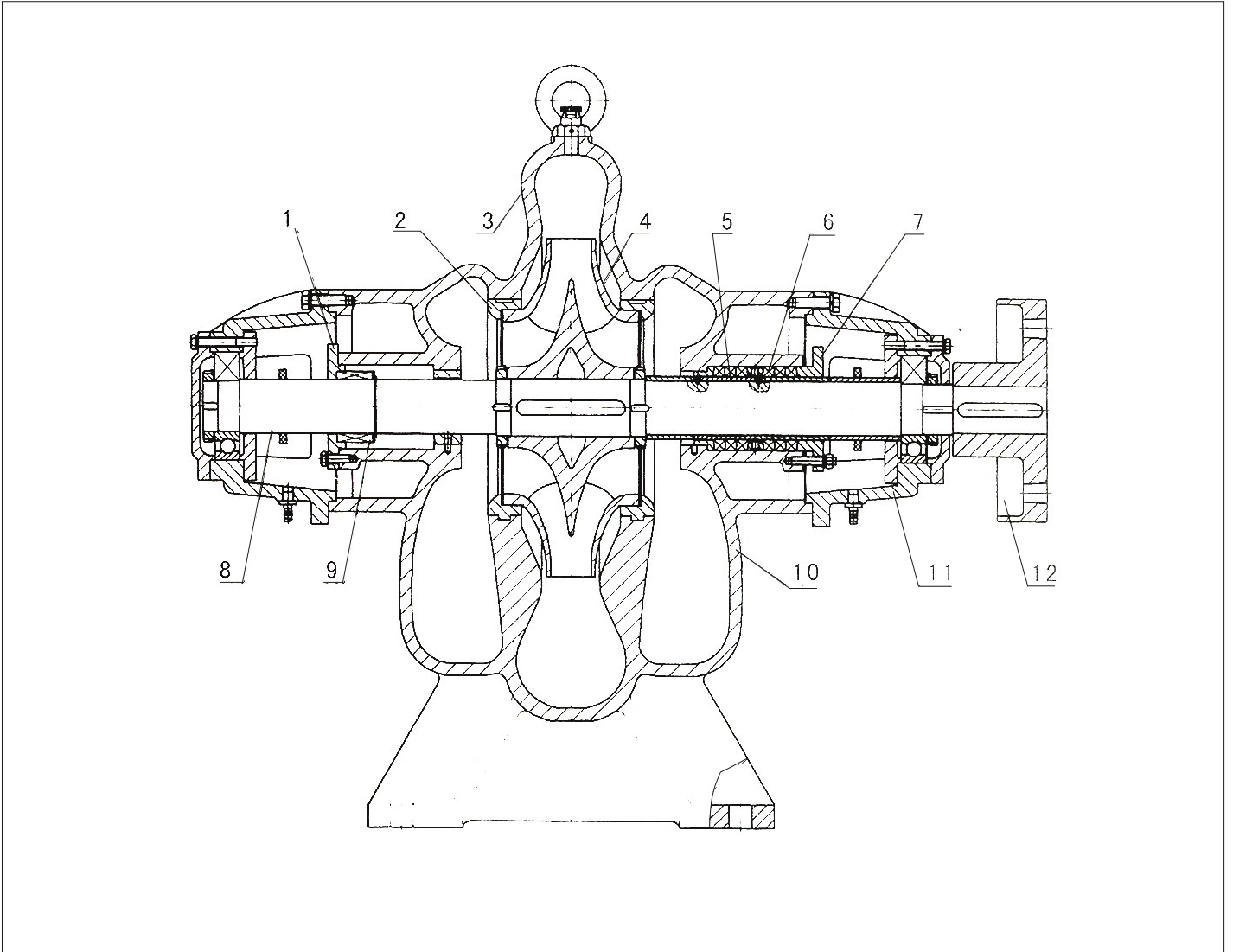

序号 Number	1	2	3	4	5	6
名称 Name	机封压盖 Gland of mechanical seal	密封环 Seal ring	泵盖 Pump cover	叶轮 Impeller	轴套 Shaft sleeve	填料 Stuffing
序号 Number	7	8	9	10	11	12
名称 Name	填料压盖 Gland of stuffing	泵轴 Shaft of pump	机械密封 Mechanical seal	泵体 Pump body	轴承体 Bearing bod	联轴器 Coupling

S型泵结构图

Performance parameter table of S Type pump

■ 性能参数表 Performance parameter table

泵型号 Pump model	流量 Flow (m³/h)	扬程 Head (m)	效率 Efficiency %	功率 Power(kW)		转速 Revolving speed r/min	气蚀余量 NPSH (m)	重量 Weight Kg
				轴功率 Shaft power	电机功率 Motor power			
150S-50	130 160 220	52 50 40	73 80.4 77	25.2 27.3 31.1	37	2950	3.9	220
150S-50A	112 144 180	44 40 35	72 75.5 70	18.6 20.0 24.5	30			
150S-50B	108 133 160	38 36 32	65 72.5 72	17.2 18.0 19.4	22			
150S-78	126 160 198	82 78 70	70 75.5 72	40 45 52	55	2950	3.7	240
150S-78A	112 144 180	67 65 55	68 72.6 70	30.1 33.4 38.5	45			
200S-42	216 280 324	48 42 35	81 84.2 81	34.8 38.1 40.2	45	2950	6	340
200S-42A	198 270 310	43 36 31	76 80 76	30.5 33.1 34.4	37			
200S-63	216 280 351	69 63 53	74 82.7 76	54.8 58.3 66.7	75	2950	5.8	320
200S-63A	180 270 324	54 46 37	70 75 70	37.8 45.1 46.6	55			
200S-95	183 280 324	103 95 87	62 79.2 75	83.1 91.4 102.4	132	2950	5.3	280
200S-95A	180 270 324	92 85 78	67 75 73	67.3 83.3 94.3	110			
200S-95B	180 280 306	82 76 68	62 70 70	64.8 73.8 80.9	90			
250S-14	360 485 576	16 14 11	80 85.8 78	19.6 21.5 22.1	30	1450	3.8	490
250S-14A	320 432 504	13 11 8	78 82.7 70	14.5 15.2 15.7	18.5			
250S-24	360 485 576	27 24 19	80 85.8 82	33.1 36.9 36.4	45	1450	3.5	530
250S-24A	324 414 482	22 20 17	80 83.3 80	25.6 27.2 27.9	37			
250S-39	360 485 612	42 39 32	76 83.6 79	54.2 61.5 67.5	75	1450	3.2	630
250S-39A	324 468 576	35 30 25	74 79 77	41.7 48.4 50.9	55			
250S-65	360 485 612	71 68 58	75 79.6 74	92.8 105.2 130.3	132	1450	3.1	520
250S-65A	342 420 540	61 58 50	74 77.7 75	77 88.5 98	110			
300S-12	612 790 900	14 12 10	80 84.8 74	29.2 30.4 33.1	37	1450	5.5	610
300S-12A	522 684 792	11 10 8	72 78.4 76	21.7 23.9 22.7	30			
300S-19	612 790 935	22 19 16	80 86.8 85	45.9 47.1 47.9	55	1450	5.2	790
300S-19A	504 720 829	20 16 13	71 80 75	38.7 39.2 39.1	45			
300S-32	612 790 900	36 32 28	80 86.8 80	75 79 86	90	1450	4.6	760
300S-32A	551 720 810	31 26 24	80 84 78	58.1 60.9 67.9	75			
300S-58	576 790 972	63 58 50	75 84.2 80	131.8 142.9 165.5	200	1450	4.4	680
300S-58A	529 720 893	53 49 42	76 82.5 78	100.5 118.0 130.9	160			
300S-58B	504 684 835	46 43 37	73 80 78	87 100 108	132			
300S-90	590 790 936	93 90 82	74 79.6 75	202 243 279	315	1450	4.2	1100
300S-90A	576 756 918	86 78 70	71 74.2 71	190 216.4 247	280			

S型泵结构图

Performance parameter table of S Type pump

■ 性能参数表 Performance parameter table

泵型号 Pump model	流量 Flow (m ³ /h)	扬程 Head (m)	效率 Efficiency %	功率 Power(kW)		转速 Revolving speed r/min	气蚀余量 NPSH (m)	重量 Weight Kg
				轴功率 Shaft power	电机功率 Motor power			
300S-90B	540 720 900	72 77 87	70 73 70	151 180 200	220	1450	4.2	1100
350S-16	972 1260 1440	20 18 13	83 85.4 74	63.8 64.4 68.9	75	1450	7.1	810
350S-16A	864 1044 1260	16 13 10	74 78.3 70	51 47 49	55			
350S-26	972 1260 1440	30 26 22	80 87.5 82	99 102 105	132	1450	6.7	940
350S-26A	864 1116 1296	26 21 16	80 83.4 73	76.5 76.9 77.4	90			
350S-44	927 1260 1476	50 44 37	81 87.5 79	163.4 172.5 188.3	220	1450	6.3	1150
350S-44A	864 1116 1332	41 36 30	80 84.5 80	121 129.5 136	160			
350S-75	972 1260 1440	80 75 65	78.5 85.2 80	271 303 319	355	1450	5.8	1320
350S-75A	900 1170 1332	70 65 56	78 84.2 79	220 244.4 257	280			
350S-75B	828 1080 1224	59 55 47	75 82.4 77	177.4 196.3 203.5	220			
350S-125	850 1260 1660	140 125 100	70 80.5 72	463 533 628	710	1450	5.4	1600
350S-125A	803 1181 1570	125 112 90	70 78.2 70	391 441 550	630			
350S-125B	745 1028 1458	108 96 77	70 77 72	313 373 425	500			
400S-40	900 1080 1260	42 40 37	80 85 84	129 140 150	185	970	5.1	1940
400S-40A	815 1007 1084	35 33 31	81 84.5 84	95.8 107 109	160			
400S-40B	725 870 967	28 26 24.7	82 84 83	67.4 73.3 78.4	110			
400S-90	1350 1620 1800	96 90 85	78 84 82	458.2 473 508	560	1450	6.2	1950
400S-90A	1215 1461 1621	78 73 69	79 84 82	327 345 371.3	450			
400S-90B	1084 1300 1445	62 58 55	82 84 82	223 245 264	315			
500S-13	1620 2020 2340	15 13 10	79 83.4 80	83.8 85.7 79.7	110	970	5.7	1500
500S-22	1620 2020 2340	24 22 19	77 84.2 85	137.5 143.6 142.4	185	970	5.2	1560
500S-22A	1400 1746 2020	20 17 14	74 80.3 75	103 100.6 102.6	132			
500S-35	1620 2020 2340	40 35 28	85 88.2 85	207.6 218.2 209.9	280	970	4.8	1640
500S-35A	1400 1746 2020	31 27 21	82 85.2 84	144 150.6 138	220			
500S-59	1620 2020 2340	67 59 47	79 83.6 80	374 388.2 374	450	970	4.5	2240
500S-59A	61500 1872 2170	57 49 39	74 75.6 72	315 332.3 320	400			
500S-59B	1620 2020 2340	67 59 47	79 83.6 80	374 388.2 374	500	1200	4.5	2240
500S-59B	1400 1746 2020	46 40 32	73 74 71	240 255.8 248	315	970	4.5	2240
500S-98	1620 2020 2340	114 98 79	78 79.5 74	664.8 678.1 680.3	800			
500S-98A	1500 1872 2170	96 83 67	77 78.5 73	509 532 542	630	970	4.1	2400
500S-98B	1400 1746 2020	86 74 59	76 78.7 75	431.4 450.1 432.8	560			
600S-22	2520 3170 3600	25 22 18	82 88 82	209.2 215.8 215.2	250	970	7	2500

S型泵结构图

Performance parameter table of S Type pump

■ 性能参数表 Performance parameter table

泵型号 Pump model	流量 Flow (m³/h)	扬程 Head (m)	效率 Efficiency %	功率 Power(kW)		转速 Revolving speed r/min	气蚀余量 NPSH (m)	重量 Weight Kg
				轴功率 Shaft power	电机功率 Motor power			
600S-22A	2160	21	81	152.5	185	970	7	2500
	2860	18	87	161.1				
	3240	16	84	168.1				
600S-32	2160	36	76	278.6	355	970	7	2500
	3170	32	89	310.4				
	3600	27	85	311.4				
600S-32A	1800	30	72	204	280	970	7	2500
	2850	26	88	229				
	3240	23	86	236				
600S-47	2160	56	80	412	560	970	6.5	3850
	3170	47	89	456				
	3600	40	86	456				
600S-47A	1980	46	78	318	450	970	6	4300
	2920	40	88	361				
	3240	37	86	380				
600S-75	2160	84	87	568	900	970	6	4300
	3170	75	88	736				
	3600	67	80	821				
600S-75A	1980	74	82	486.6	710	970	6	4300
	2950	65	87	600.2				
	3240	60	80	661.8				
600S-75B	1800	60	80	367.6	560	970	6	4300
	2710	55	85	477.5				
	3060	51	80	531.3				
600S-100	2160	110	78	829.6	1250	970	6	4300
	3170	100	85	1015.6				
	3600	92	84	1073.8				
600S-100A	1980	100	78	697.3	1120	970	6	4300
	3000	90	84	875.4				
	3240	85	82	914.6				
600S-100B	1800	90	75	588.2	900	970	6	4300
	2830	80	82	751.9				
	3060	75	80	781.3				
800S-22	4320	25	82	358.7	450	730	7	4500
	5500	22	89	370.2	500			
	6480	19	86	389.9				
800S22A	3000	16	80	163.4	250	585	5	4500
	4400	14	88	190.6				
	5040	12	85	193.8				
800S22A	3960	19	83	246.9	315	730	7	4500
	4830	17	88	254.1				
	5500	15	86	261.2				
800S-32	2800	13	80	123.9	185	585	5	4500
	3870	11	87	133.3				
	4500	9	84	131.3				
800S-32	4320	35	82	502.2	630	730	7	5100
	5500	32	89	538.5				
	6480	29	87	588.2				
800S-32A	3000	23	80	234.9	315	585	4.5	5100
	4400	20	88	272.3				
	5200	18	85	299.9				
800S-32A	3500	30	81	353	450	730	7	5100
	4950	26	88	389				
	6000	23	86	437				
800S-32A	2700	19	80	174.6	250	585	4.5	5100
	3960	17	87	210.7				
	4680	14	84	212.4				
800S-47	4320	51	81	740.7	1000	730	6.5	7300
	5500	47	90	782.2				
	6480	42	88	842.2				
800S-47	3000	35	80	357.4	450	585	4.2	7300
	4400	30	89	403.9				
	5200	26	86	428.1				
800S-47A	3500	45	81	530	710	730	6.5	7300
	5070	40	89	621				
	6000	36	86	684				
800S-47A	2800	30	80	285.9	355	585	4.2	7300
	4060	25	88	314.1				
	4800	22	86	334.4				
800S-76	4000	70	79	1103.1	1600	730	6	7900
	5500	76	88	1293.6				
	6500	71	87	1444.6				
800S-76	3000	54	80	551.5	800	585	4.2	7900
	4400	49	87	674.9				
	5500	43	85	757.7				
800S-76A	3500	70	79	845	1250	730	6	7900
	5080	65	87	1034				
	6000	62	84	1206				
800S-76A	2800	48	79	463	630	585	4.2	7900
	4070	42	86	541				
	5000	37	83	607				
800S-76B	3000	60	78	628.6	1000	730	6	7900
	4680	55	85	824.7				
	5500	51	83	920.3				
800S-76B	2500	40	76	358.3	500	585	4.2	7900
	3750	35	84	425.3				
	4500	30	80	459.6				

S型泵性能曲线图

Performance curve S Type pump

性能曲线图 Performance curve

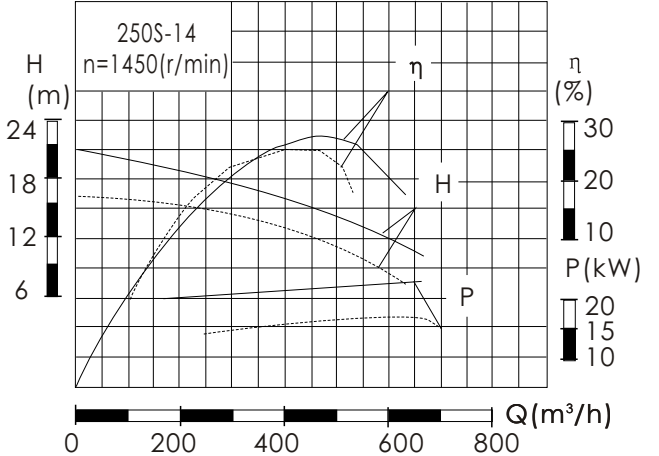
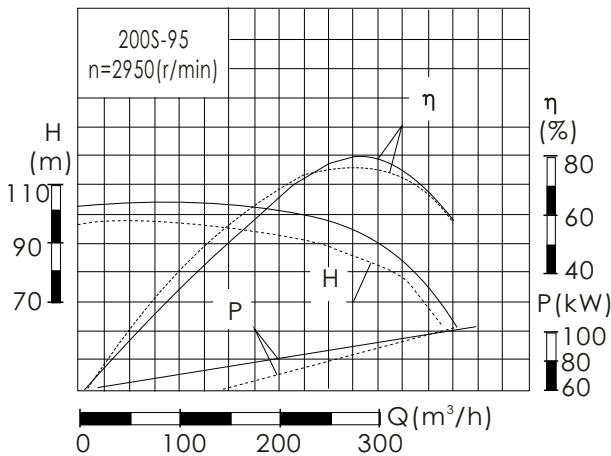
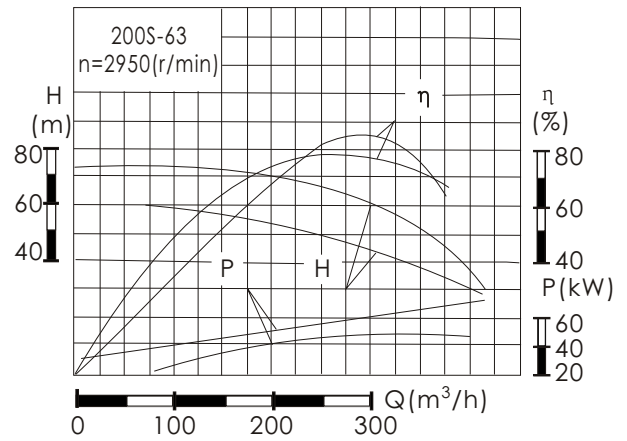
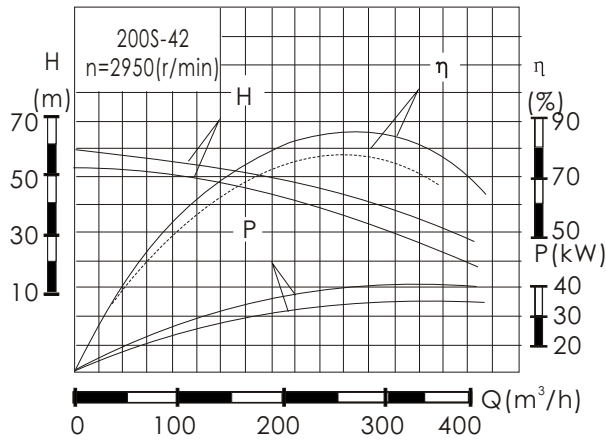
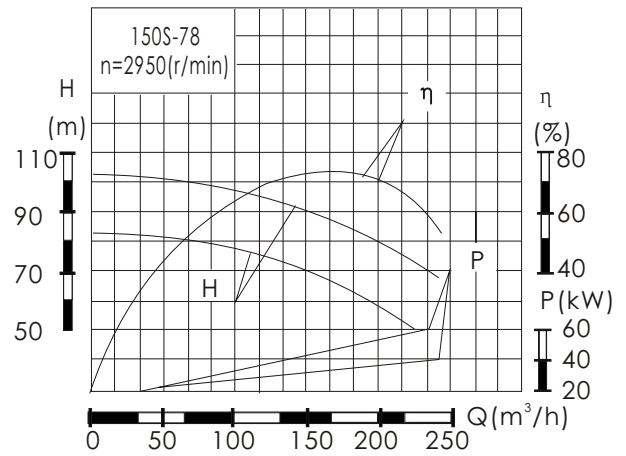
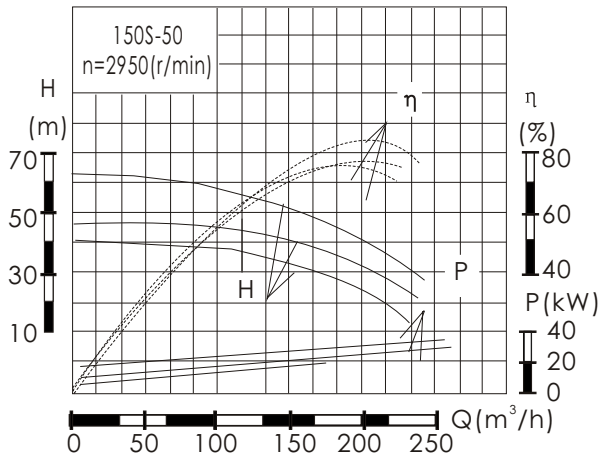

S型泵性能曲线图

Performance curve S Type pump

性能曲线图 Performance curve

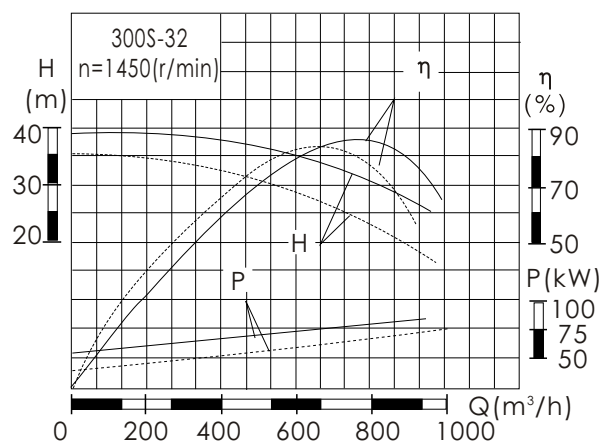
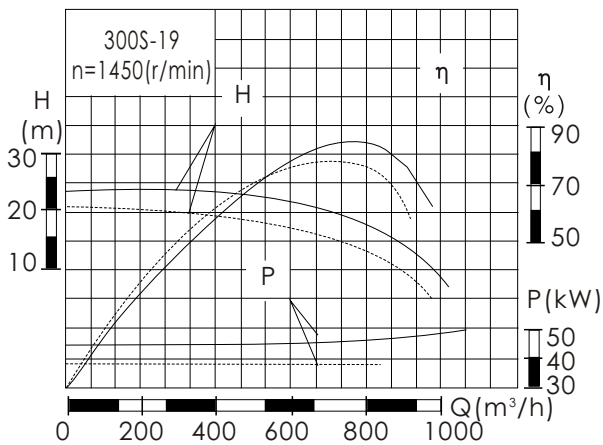
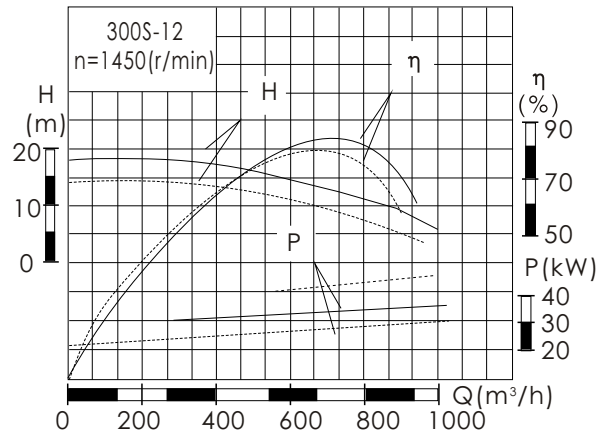
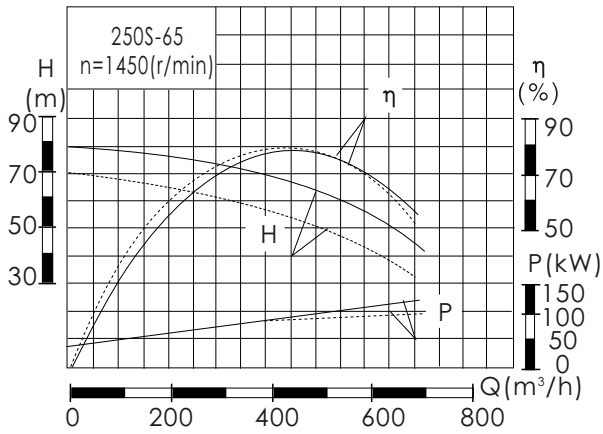
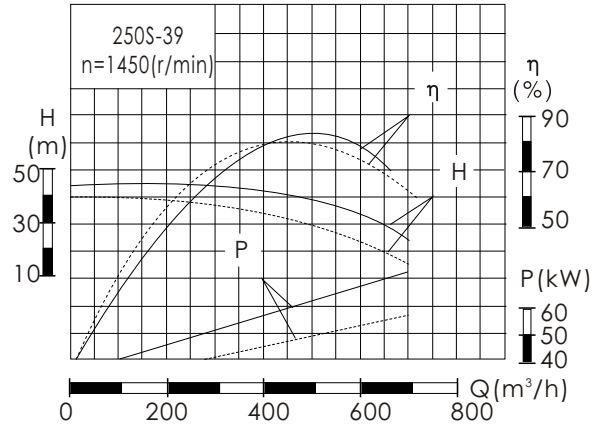
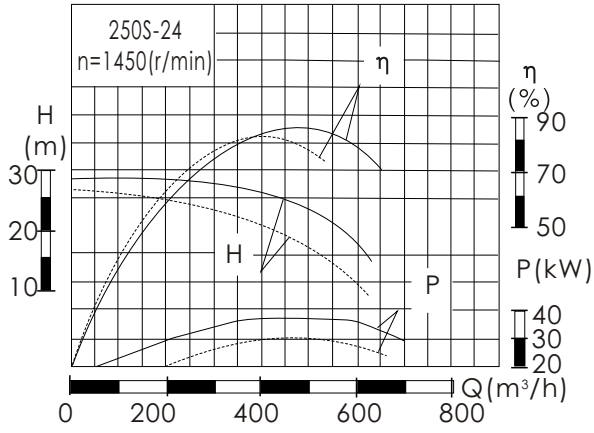

S型泵性能曲线图

Performance curve S Type pump

性能曲线图 Performance curve

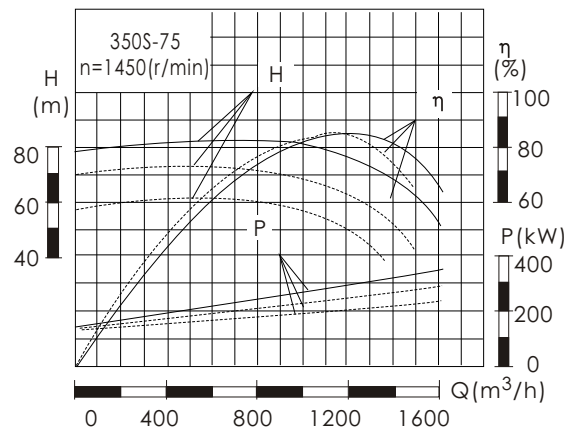
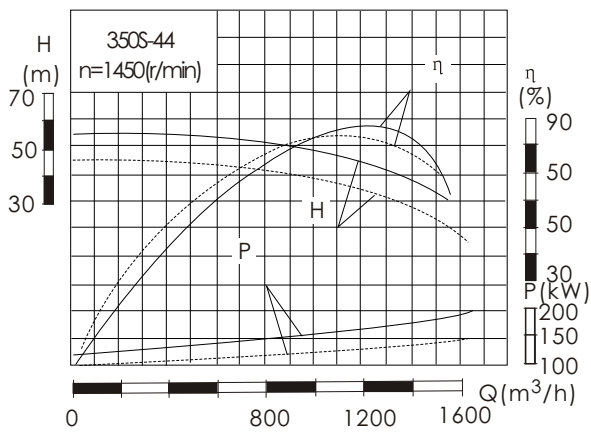
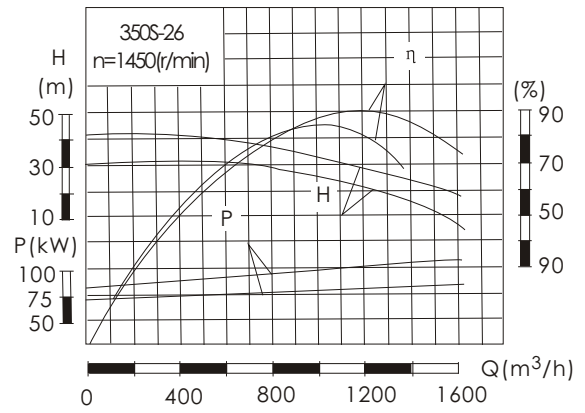
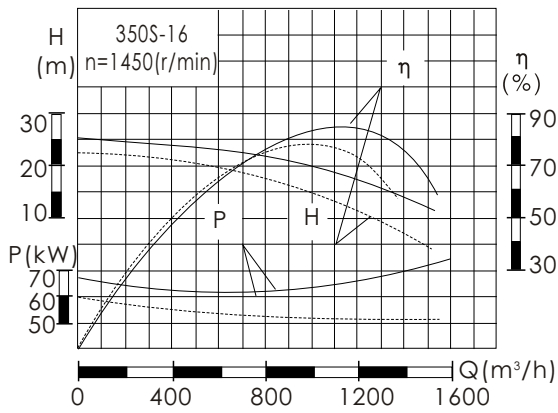
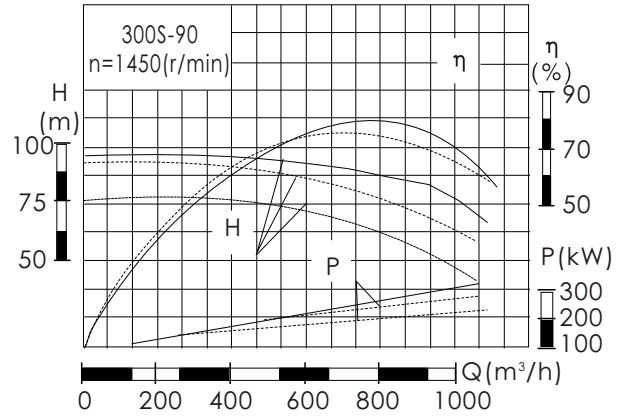
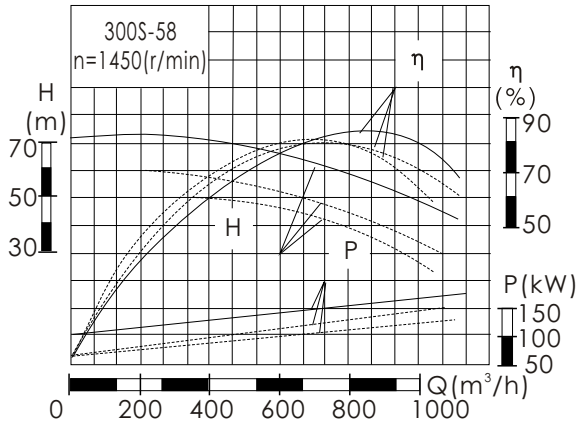

S型泵性能曲线图

Performance curve S Type pump

性能曲线图 Performance curve

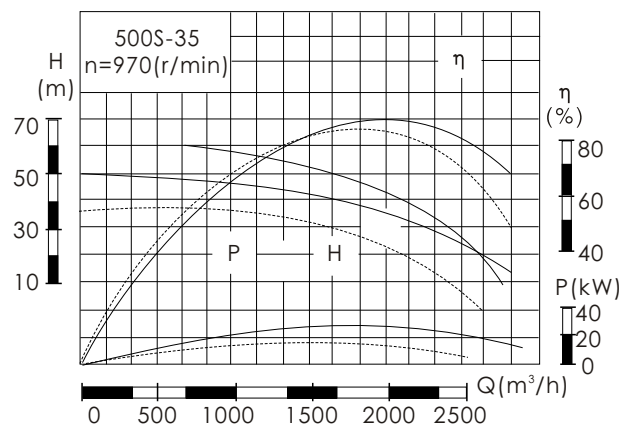
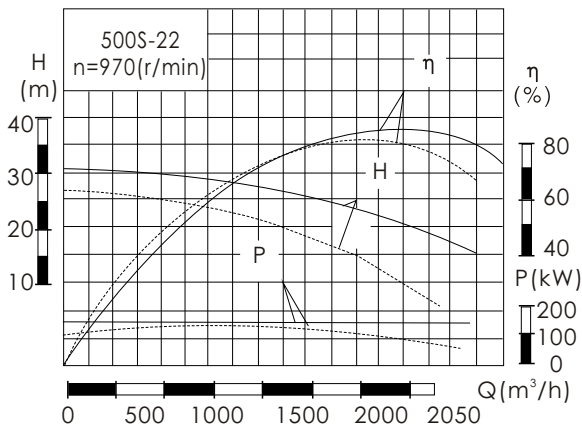
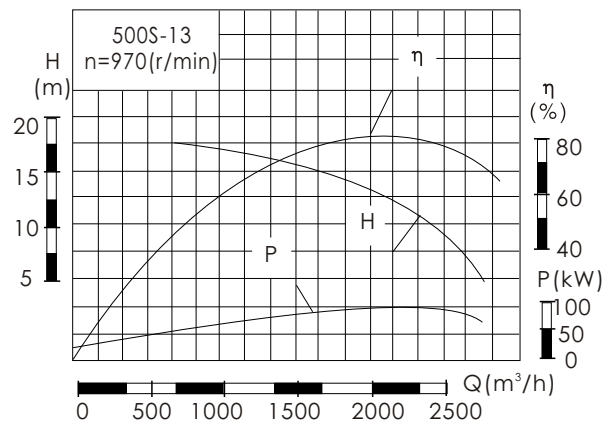
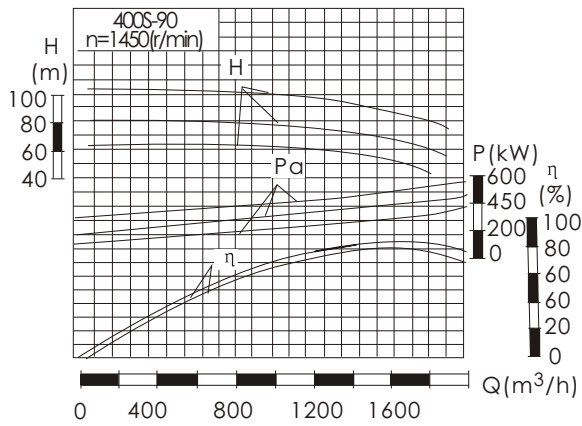
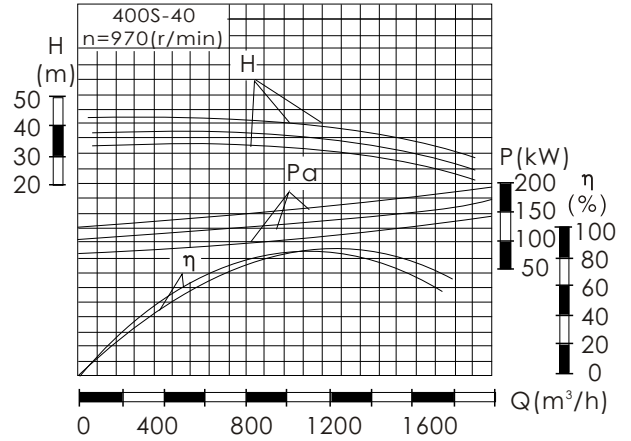
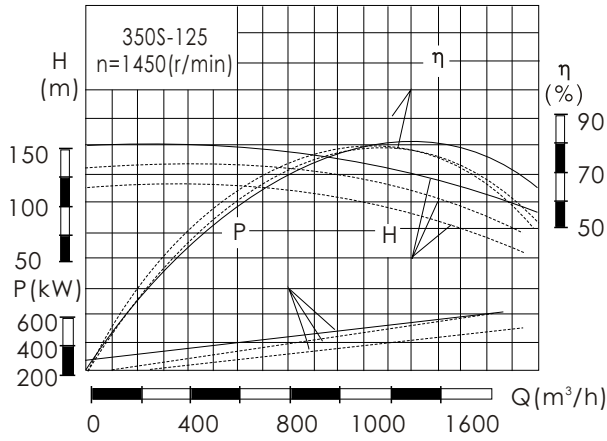

S型泵性能曲线图

Performance curve S Type pump

性能曲线图 Performance curve

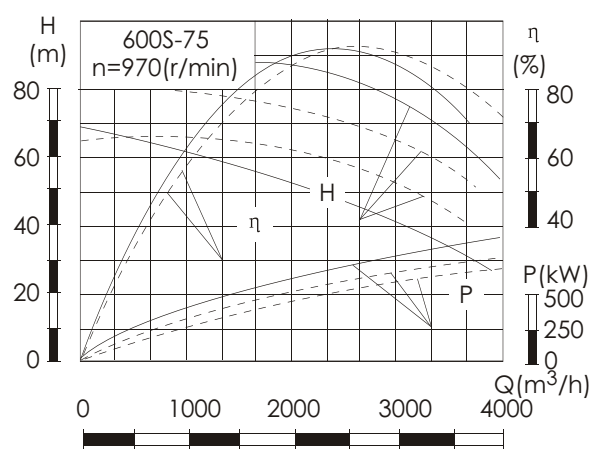
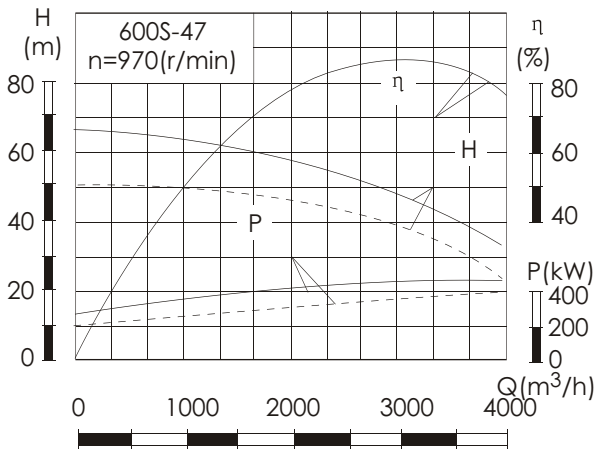
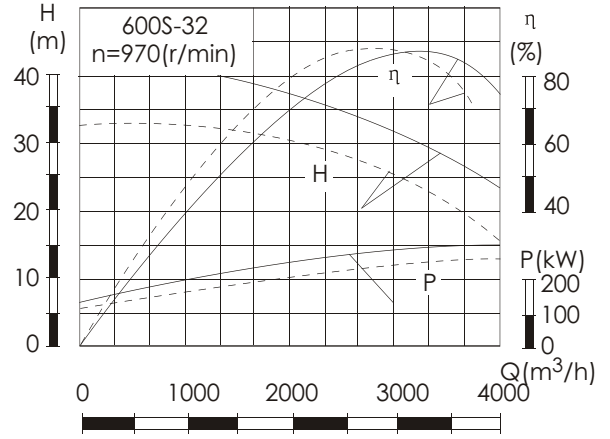
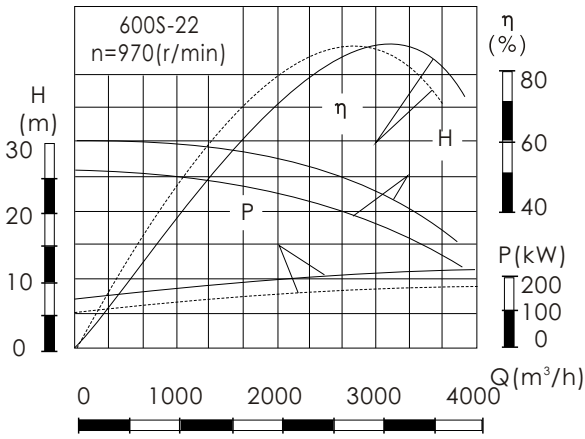
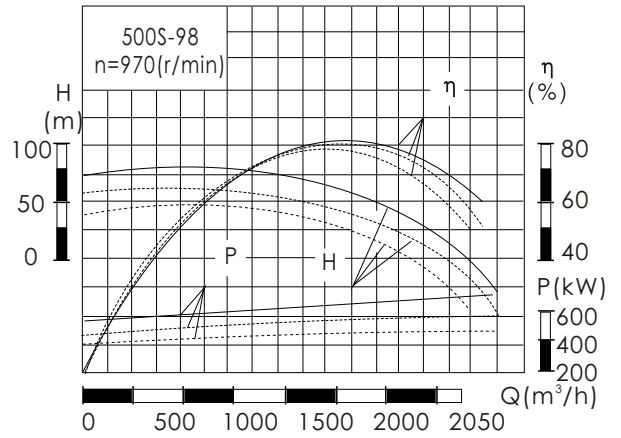
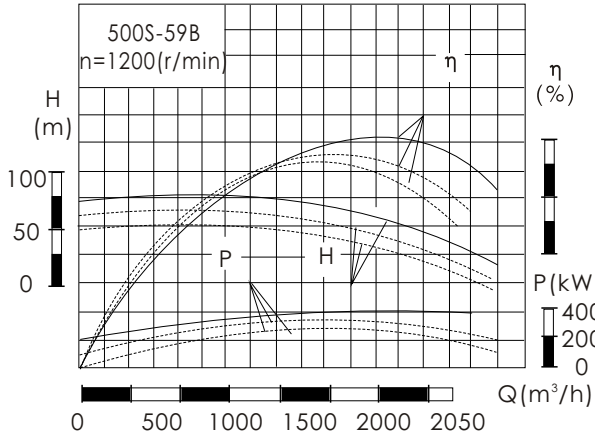

S型泵性能曲线图

Performance curve S Type pump

性能曲线图 Performance curve

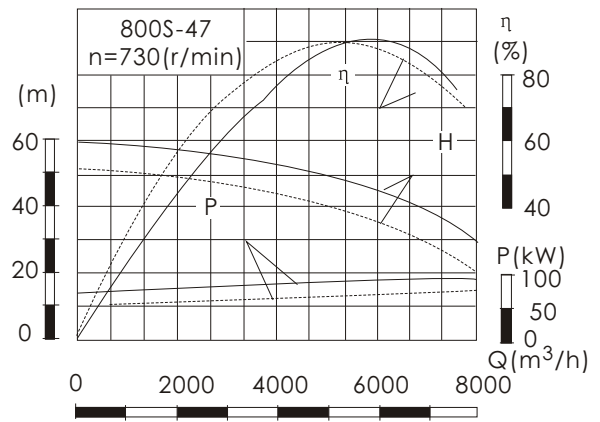
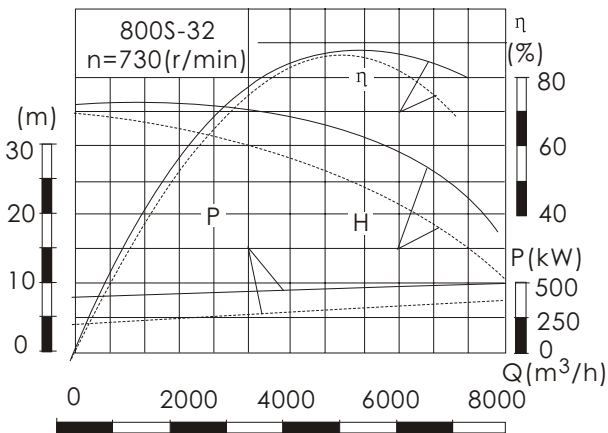
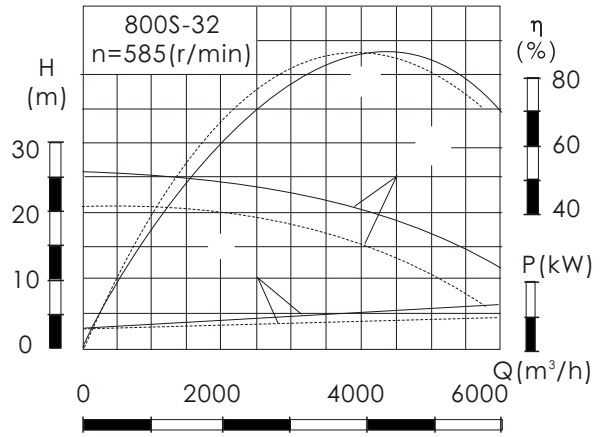
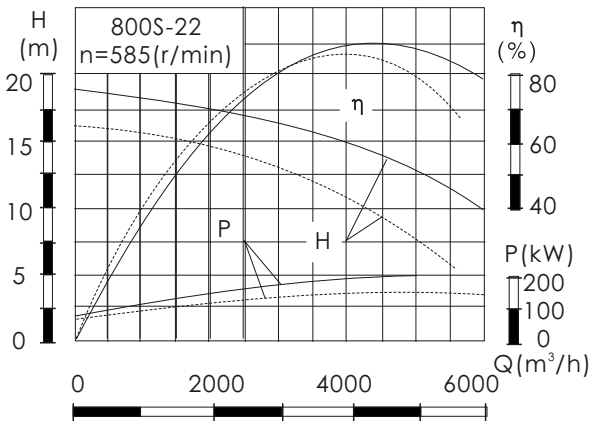
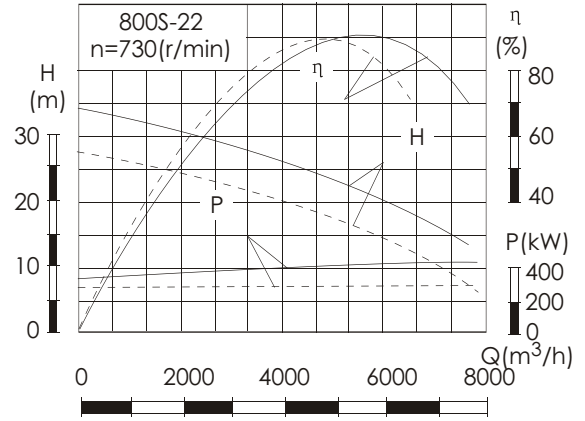
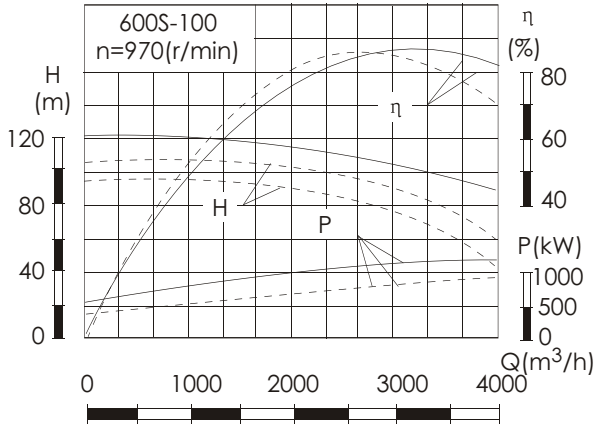

S型泵性能曲线图

Performance curve S Type pump

性能曲线图 Performance curve

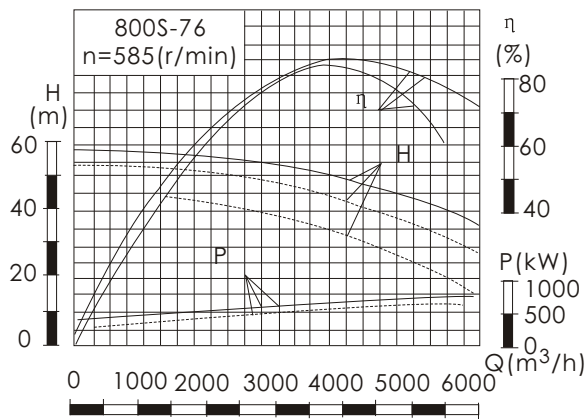
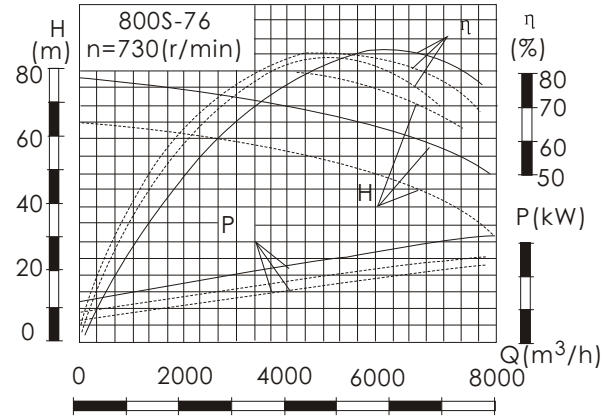
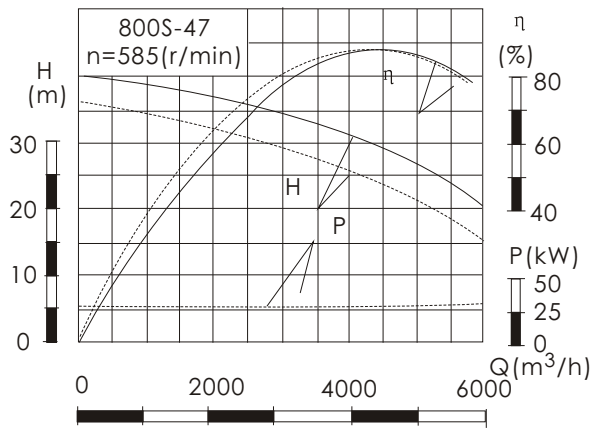

■ 带底座外形安装尺寸图表 Outline installation dimension drawing with baseplate

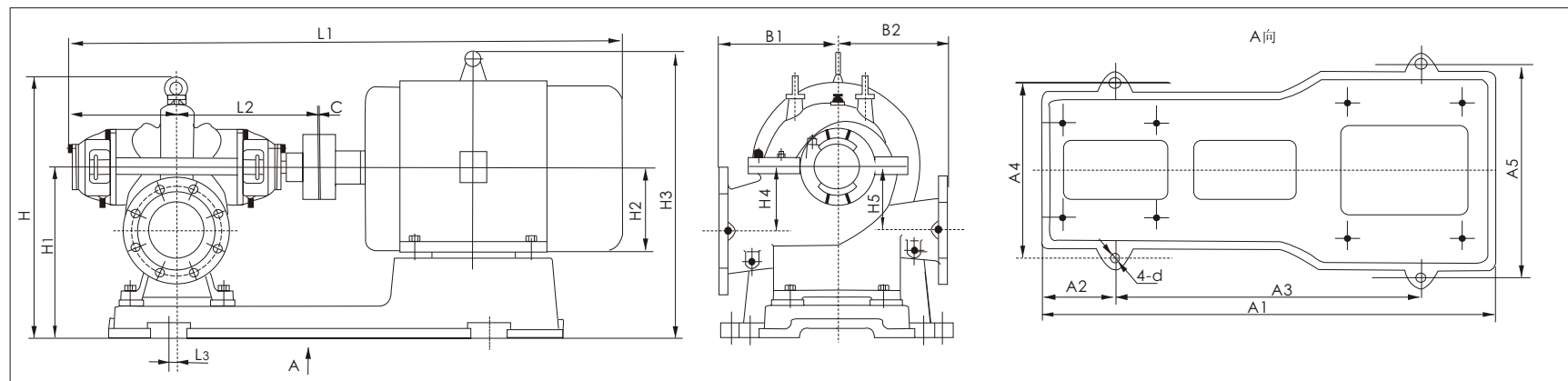

泵型号 Pump model	电机 Motor			外形尺寸 Outline dimension										C	底座尺寸 Baseplate dimension																																																																																																																						
	型号 Model	功率 (kW) Power	电压 (V) Voltage	L	L1	L2	L3	H	H1	H2	H3	H4	H5		B1	B2	A1	A2	A3	A4	A5	d																																																																																																															
150S-50	Y200L2-2	37	380	1410	270	359	13	617	385	200	730	140	140	300	250	1180	173	800	430	500	φ25																																																																																																																
150S-50A	Y200L1-2	30								180	660																																																																																																																										
150S-50B	Y180M-2	22								1340	282											372	10	635	385	250	750	140	155	300	250	1305	173	875	430	585	φ25																																																																																																
150S-78	Y250M-2	55								1590																225	715					1210		820		540																																																																																																	
150S-78A	Y225M-2	45								1480																292	381					-15		697		455		225	790	170	170	320	300	1225	198	827	465	564	φ25																																																																																				
200S-42	Y225M-2	45								1500																												200	760					1200		808		564																																																																																					
200S-42A	Y200L2-2	37								1450																												305	394					10		697		455		280	855	170	170	320	300	1400	173	930	430	655	φ25																																																																								
200S-63	Y280S-2	75								1700																																								250	760					1335		900		600																																																																									
200S-63A	Y250M-2	55								1640																																								380	469					-1		850		570		200	915	210	215	415	330	1360	241	880	625	560	φ25																																																												
250S-14	Y200L-4	30								1630																																																				180	845					1285		840		525																																																													
250S-14A	Y180M-4	18.5								1560																																																				395	486					-1		902		570		225	900	230	230	450	400	1430	241	950	625	625	φ25																																																
250S-24	Y225M-4	45								1730																																																																280	970					1570		1072		735																																																	
250S-24A	Y225S-4	37								1700																																																																405	496					-18		918		570		250	935	200	260	450	440	1505	258	1005	665	665	φ30																																				
250S-39	Y280S-4	75								1900																																																																												225	965					1547		1000		685																																					
250S-39A	Y250M-4	55								1840																																																																												463	554					2.5		966		630		200	935	265	265	500	500	1535	305	951	770	605	φ30																								
300S-12	Y225S-4	37								1840																																																																																								250	995					1610		1024		700																									
300S-12A	Y200L-4	30								1800																																																																																								423	514					2.5		982		630		225	960	250	260	500	400	1547	305	1000	770	685	φ30												
300S-19	Y250M-4	55								1880																																																																																																				250	995					1610		1024		700													
300S-19A	Y225M-4	45								1790																																																																																																				431	540					13.5		996		630		280	1030	260	270	470	410	1730	283	1118	690	690	φ30
300S-32	Y280M-4	90								2030																																																																																																																225	960					1547		1000		685	
300S-32A	Y250S-4	75	1980	431	540	13.5	996	630	280	1030		260	270	470	410	1730	283	1118	690	690	φ30																																																																																																																

S型泵外形安装尺寸图表
Outline installation dimension drawing for S type pump

■ 不带底座外形安装尺寸图表 Outline installation dimension drawing without baseplate

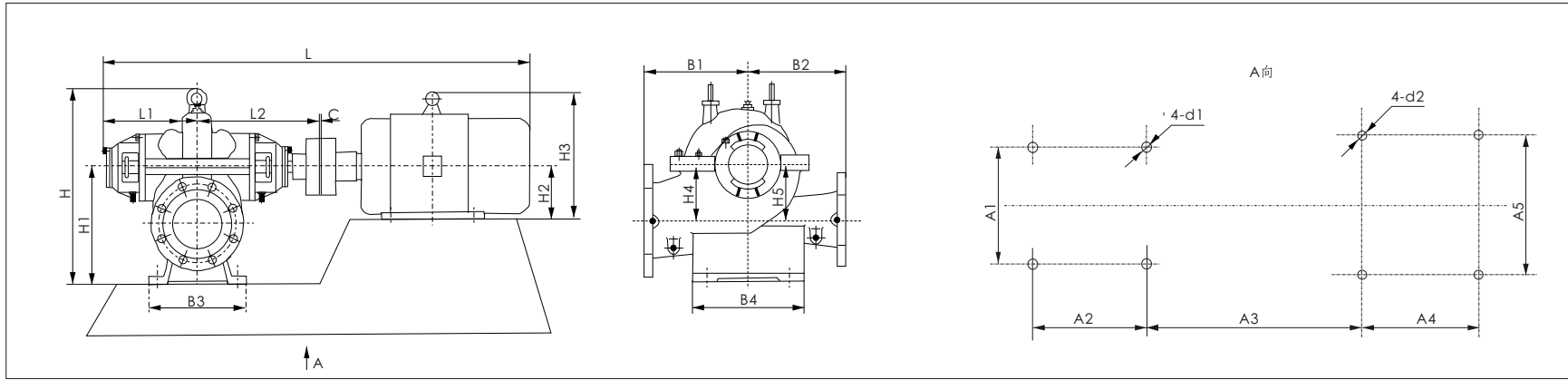

泵型号 Pump model	电机 Motor			外形尺寸 Outline dimension											C	底座尺寸 Baseplate dimension										
	型号 Model	功率 (kW) Power	电压 (V) Voltage	L	L1	L2	H	H1	H2	H3	H4	H5	B1	B2		B3	B4	A1	A2	A3	A4	A5	d1	d2		
200S-95	Y315M-2	132	380	2080					315	845							250	250	684	457	508		Φ 28			
200S-95A	Y315S-2	110		2050	357	448	627	355			170	170	350	300	300	340				406			Φ 18			
200S-95B	Y280M-2	90		1860					280	680										658	419	457		Φ 24		
250S-65	Y315M-4	132		2220					315	845								400	350	728	457	508		Φ 28		
200S-65A	Y280M-4	90		1970	403	512	815	450	280	680	240	290	480	400	410	570				672	419	457		Φ 27		
300S-58	Y315L2-4	200																								
300S-58A	Y315L1-4	160		2320	453	562	897	510	315	845	240	310	540	530	510	620				728	508	508		Φ 27		
300S-58B	Y315M-4	132																			457				Φ 28	
300S-90	Y355-4	315		6000	3090	522	666	1011	550	355	740	260	340	576	470	520	600	450	450	971	900	630		Φ 27	Φ 28	
300S-90A	Y366-4	280																								
300S-90B	Y355-4	220																								
350S-16	Y280S-4	75	380		2100					280	680							500	500	676	368	457		Φ 34	Φ 24	
350S-16A	Y250M-4	55		2030	500	591	1020	620	250	615	310	310	584	584	600	690				654	349	406				
350S-26	YY315M-4	132		2390					315	845										736	457	508		Φ 34	Φ 28	
300S-26A	Y280M-4	90		2140	486	595	991	620	280	680	290	300	580	460	580	680				680	419	457		Φ 34	Φ 24	
350S-44	Y355M1-4	220		2750					355	1010											857	560	610		Φ 34	Φ 28
350S-44A	Y315L1-4	160		2520	534	678	1062	620	315	845	300	300	570	510	600	690				819	508	508		Φ 34	Φ 28	
350S-75	Y400-4	355		3260					400	830											1005	1000	710		Φ 35	
350S-75A	Y355-4	280		3170	562	705	1125	620	355	740	260	360	650	650	600	690				985	900	630		Φ 34	Φ 28	
350S-75B	Y355-4	220																								
350S-125	Y450-4	710	6000	3620				450	930								550	500	1129	1120	800		Φ 35	Φ 35		
350S-125A	Y450-4	630		3420	622	809	1082	620			330	410	660	550	600	690										
350S-125B	Y450-4	500							400	830											1109	1000	710			

■ 不带底座外形安装尺寸图表 Outline installation dimension drawing without baseplate

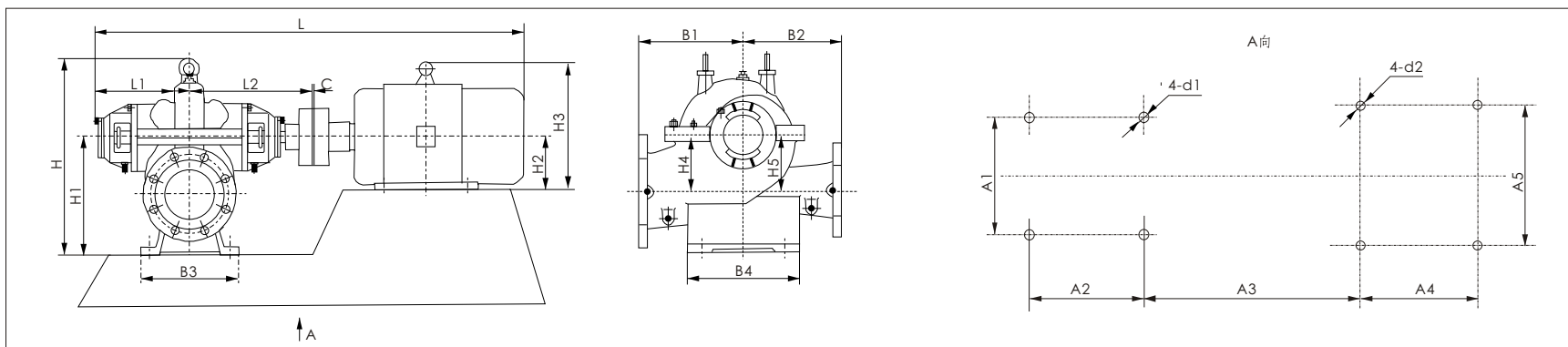

泵型号 Pump model	电机 Motor			外形尺寸 Outline dimension													C	底座尺寸 Baseplate dimension											
	型号 Model	功率 (kW) Power	电压 (V) Voltage	L	L1	L2	H	H1	H2	H3	H4	H5	B1	B2	B3	B4		A1	A2	A3	A4	A5	d1	d2					
400S-40	Y355M-6	185	380	2980	635	805	1130	670	355	1010	334	382	745	800	820	900	6	700	700	885	560	610	Φ35	Φ28					
400S-40A	Y355M1-6	160		2750					315	845										847	508	508							
400S-40B	Y315L1-6	110		3430					400	830										1006	1000	710			Φ35	Φ35			
400S-90	Y400-4	560	6000	635	805	1130	670	400	830	334	382	745	800	820	900	700		700	1006	1000	710	Φ35	Φ28						
400S-90A	Y400-4	450						3340	355										740	986	900			630					
400S-90B	Y355-4	315						3340	355										740	986	900			630	Φ35	Φ28			
500S-13	Y315L1-6	110	380	2770	670	790	1431	800	315	845	400	400	730	650	740	920		8	720	600	884	508	508	Φ42	Φ28				
500S22	Y355M-6	185		2950	634	778	1310	800	355	1010	430	455	730	650	740	920					720	600	910			560	610	Φ42	Φ28
500S-22A	Y315L2-6	132		2720	315	845	872	508	508																				
500S-35	Y400-6	280	6000	624	768	1335	800	400	830	415	415	720	630	760	1020	800			580	1031	1000	710	Φ42	Φ35					
500S-35A	Y355-6	220						3290	355											740	1011	900			630	Φ42	Φ28		
500S-59	Y450-6	450						3570	450											930	983	1120			800	Φ42	Φ35		
500S-59A	Y400-6	400	3370	621	760	1485	900	400	830	425	500	800	750	910	1100	800	780		923	1000	710	Φ42	Φ35						
500S-59B	YKK500-6	500	3989																400	830	1248			1120	800			Φ42	Φ42
500S-59B	Y400-6	315	3370																400	830	923			1000	710	Φ42	Φ35		
500S-98	Y500-6	800	6000	4470	880	1025	1641	900	500	1030	425	545	800	750	910	1100	800		780	1368	1250	900	Φ42	Φ35					
500S-98A	Y450-6	630		4100					450	930										1248	1120	800			Φ42	Φ35			
500S-98B	Y450-6	560		4100					450	930										1248	1120	800			Φ42	Φ35			
600S-22	Y355-6	250	380	3370	662	810	1490	950	355	740	460	460	950	840	940	1020	800	760	1063	900	630	Φ42	Φ28						
600S-22A	Y355M-6	185		3010					355	1010									862	560	610								
600S-32	Y400-6	355		3780					836	955									1710	900	400			830	500	530	840	750	940
600S-32A	Y400-6	280	6000	4130	857	1085	1700	950	450	930	532	663	1000	800	1100	1300	1000	900	1248	1120	800	Φ42	Φ35						
600S-47	Y450-6	560							4130	450									930	1248	1120			800	Φ42	Φ35			
600S-47A	Y450-6	450							4130	450									930	1248	1120			800	Φ42	Φ35			

■ 不带底座外形安装尺寸图表 Outline installation dimension drawing without baseplate

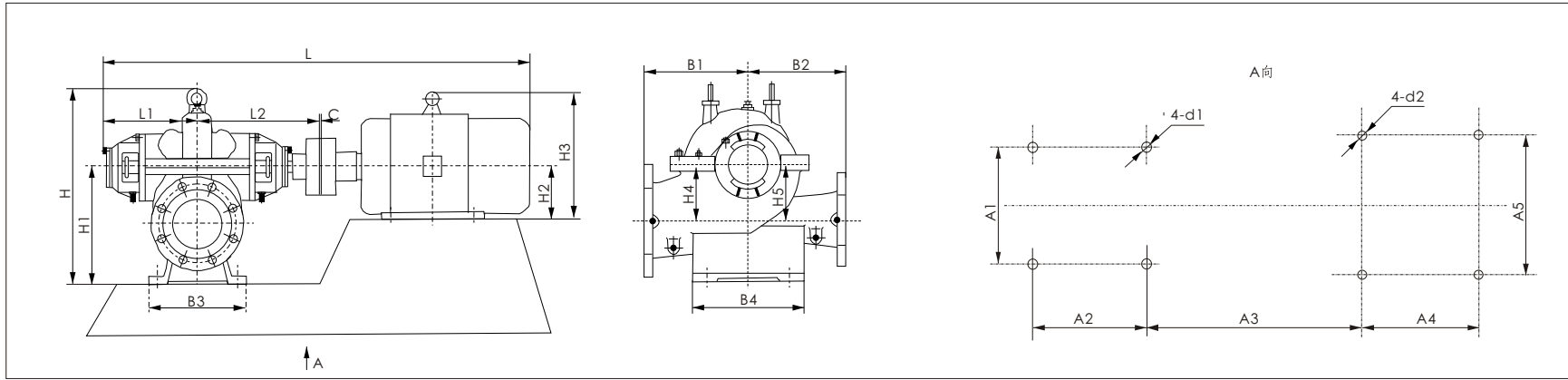

泵型号 Pump model	电机 Motor			外形尺寸 Outline dimension											C	底座尺寸 Baseplate dimension							
	型号 Model	功率 (kW) Power	电压 (V) Voltage	L	L1	L2	H	H1	H2	H3	H4	H5	B1	B2		B3	B4	A1	A2	A3	A4	A5	d1
600S-75	Y500-6	900	6000	4590	944	1085	1706	950	500	1030	532	663	1000	800	1100	1000	100	900	1368	1250	900	Φ42	Φ42
600S-75A	Y500-6	710		4220					450	930									1248	1120	800		
600S-75B	Y450-6	560		4810	840	1060	1600	950	560	1148	490	590	1200	900	940	1020	800	760	1488	1400	1000	Φ42	Φ42
600S-100	Y560-6	1250		4460					560	1030									1413	1250	900		
600S-100A	Y560-6	1120		5100	880	1120	2014	1200	500	2200	720	720	1350	750	1200	1200	1000	1000	1453	1250	900	Φ42	Φ42
600S-100B	Y500-6	900		4410	1000	1220	2210	1265	450	930	755	695	1400	750	1200	1200	900	1000	1333	1120	800		
800S-22	YK5003-8	500	3760	380	3760	2210	1265	355	1010	355	1010	1400	750	1200	1200	900	1000	1152	630	610	Φ28	Φ28	
800S-22A	Y450-8	450	4680					500	1030									1403	1250	900			Φ42
800S-32	Y450-8	315	4310	950	1170	1920	1200	450	930	640	640	1250	1000	1200	1300	1000	1000	1283	1120	800	Φ48	Φ35	
	800S-22A	Y355L-10						185	5660									560	1148	1403			1250
800S-32A	Y500-8	630	5310	1240	1510	2105	1250	500	1030	700	850	1280	1000	1300	1700	1350	1000	1743	1250	900	Φ48	Φ42	
	800S-32A	Y450-10						315	4940									450	930	1623			1120
800S-47	Y560-8	1000	5840	1272	1455	2105	1250	630	1350	730	900	1360	1088	1300	1700	1350	1000	1793	1600	1120	Φ48	Φ48	
	800S-47A	Y500-10						450	5640									560	1148	1763			1400
800S-76	Y630-8	1600	5840	1272	1455	2105	1250	630	1350	730	900	1360	1088	1300	1700	1350	1000	1793	1600	1120	Φ56	Φ48	
	800S-76A	Y500-10						800	5290									500	1030	1688			1250
800S-76A	Y630-8	1250	5640	1272	1455	2105	1250	500	1030	730	900	1360	1088	1300	1700	1350	1000	1763	1400	1000	Φ56	Φ48	
	800S-76A	Y500-10						630	5290									500	1030	1688			1250
800S-76B	Y560-8	1000	5290	1272	1455	2105	1250	560	1148	730	900	1360	1088	1300	1700	1350	1000	1763	1400	1000	Φ42	Φ42	
	800S-76B	Y500-10						500	5290									500	1030	1688			1250

S型泵进出口法兰尺寸图表

Flange dimension table of inlet & outlet for S type pump

■ 法兰尺寸图 Flange dimension drawing

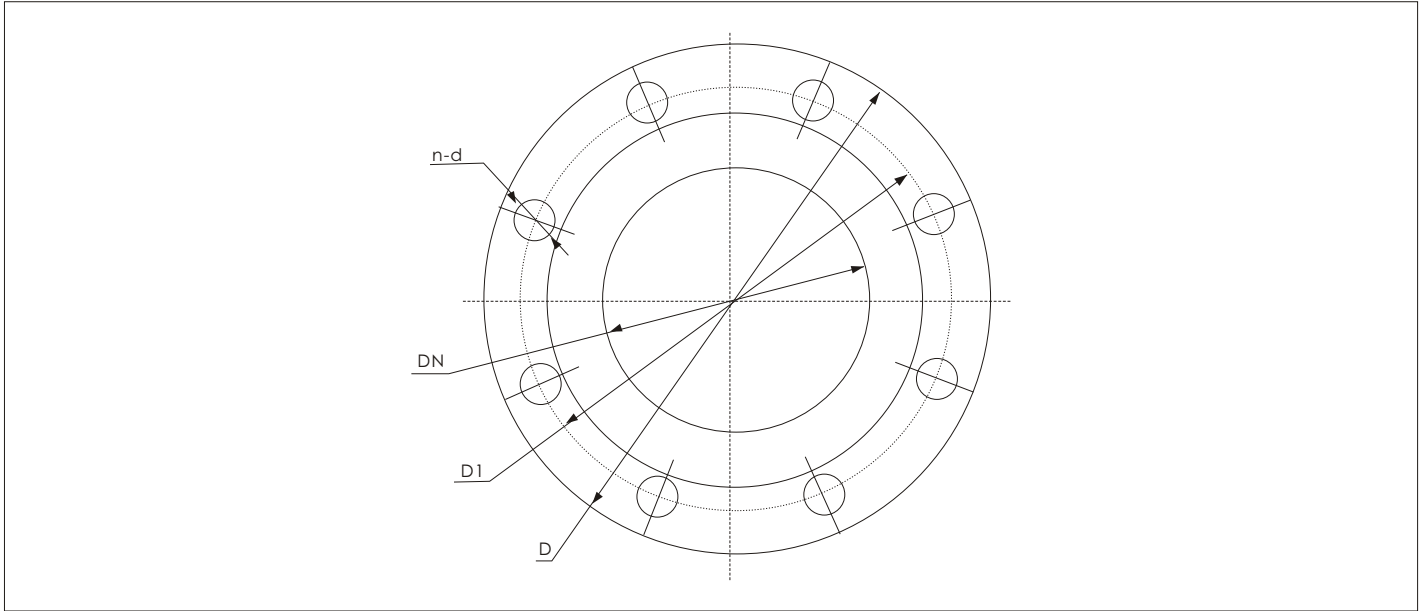

■ 法兰尺寸表 Flange dimension table

型号 Model	进口法兰 Flange of inlet				出口法兰 Flange of outlet			
	DN	D1	D	n-d	DN	D1	D	n-d
150S-50	Φ150	Φ240	Φ285	8-Φ23	Φ100	Φ180	Φ220	8-Φ18
150S-78					Φ150	Φ240	Φ285	8-Φ23
200S-42	Φ200	Φ295	Φ340	8-Φ23	Φ125	Φ210	Φ250	8-Φ18
200S-63					Φ150	Φ240	Φ285	8-Φ23
200S-95								
250S-14	Φ250	Φ350	Φ395	12-Φ23	Φ200	Φ295	Φ340	8-Φ23
250S-24					Φ150	Φ240	Φ285	8-Φ23
250S-39					Φ300	Φ400	Φ445	12-Φ23
250S-65					Φ200	Φ295	Φ340	8-Φ23
300S-12	Φ300	Φ400	Φ445	12-Φ23	Φ300	Φ400	Φ445	12-Φ23
300S-19					Φ250	Φ350	Φ395	12-Φ23
300S-32					Φ200	Φ295	Φ340	8-Φ23
300S-58					Φ250	Φ460	Φ505	12-Φ23
300S-90					Φ300	Φ400	Φ445	12-Φ23
350S-16	Φ350	Φ460	Φ505	16-Φ27	Φ250	Φ460	Φ505	12-Φ23
350S-26					Φ300	Φ400	Φ445	12-Φ23
350S-44					Φ250	Φ350	Φ395	12-Φ23
350S-75					Φ250	Φ355	Φ405	12-Φ275
300S-125					Φ250	Φ355	Φ405	12-Φ275
500S-13	Φ500	Φ620	Φ670	20-Φ27	Φ500	Φ620	Φ670	20-Φ27
500S-22					Φ400	Φ515	Φ565	16-Φ27
500S-35					Φ350	Φ460	Φ505	16-Φ23
500S-59					Φ350	Φ460	Φ505	16-Φ23
500S-98					Φ650	Φ715	Φ780	20-Φ33
800S-22					Φ800	Φ950	Φ1015	24-Φ33

S型泵起动与停车、维护

Start, stop and maintenance for S type pump

■ 起动前准备Ready before starting

- 用手拨动电机风叶，叶轮应无卡磨现象，转动灵活。
Moving the motor vane by hand, the impeller shouldn't rub, the rotation is nimble.
- 打开进口阀门、打开排气阀使液体充满整个泵腔，然后关闭排气阀。
Open inlet valve and discharge valve to fill whole pump with liquid, then close discharge valve after it is full.
- 用手盘动泵以使润滑液进入机械密封端面。
Start pump by hand, to make lubrication enter into mechanical seal surface.
- 点动电机，确定转向是否正确。
Start motor, check revolving direction is right or not.

■ 起动与运行Start and running

- 全开进口阀门，关闭吐出管路阀门。
Full-open inlet valve, close the valve of discharge pipeline.
- 接通电源、当泵达到正常转速后，再逐渐打开吐出管道上的阀门，并调节到所需工况。
Turn on power source, open the valve on discharge pipeline to regulate work condition after revolving speed of pump keep normal.
- 注意观察仪表读数，检查轴封泄漏情况，正常时机械密封泄漏量 < 3滴/分，填料泄漏量 < 10ml/h。
Observing gauge data carefully, checking the leakage condition of shaft's seal. When it is normal, the leakage quantity of mechanical seal is < 3 drop/minute, the leakage quantity of stuffing is < 10 ml/h.
- 检查电机、轴承处温升 $\leq 70^{\circ}\text{C}$ ，如果发现异常情况，应及时处理。
Check the motor and bearing, its temperature should be $\leq 70^{\circ}\text{C}$, if they aren't normal, it should treat in time.

■ 停车Stop

- 逐渐关闭吐出管路阀门，切断电源。
Close the valve of discharge pipeline, turn off power source.
- 关闭进口阀门
Close the valve of inlet.
- 如环境温度低于 0°C ，应将泵内液体放尽，以免冻裂。
If ambient temperature is lower than 0°C , all the liquid in pump should discharge to avoid freezing and cracking.
- 如长期停用，应将泵拆卸清洗，加防锈油，包装保管。
If unit keeps stop condition for long time, we should disassemble pump and coat rust-proof grease on it.

■ 运行中的维护Maintenance during operation

- 进口管道必须充满液体、禁止泵在汽蚀状态下长期运行。
Inlet pipeline should full with liquid, prohibit pump to operate in cavitate condition;
- 定时检查电机电流值，不用超过电机额定电流。
Check the current value of motor periodically, it shouldn't higher than rated current of motor;
- 泵进行长期运行后，由于机械磨损，使机组噪音及振动增大时，应停车检查，必要时可更换易损件，机组大修期一般为一年。
If pump operates for long time, you should replace damageable parts and check unit periodically, the check time is one year in a general way.

■ 机构密封维护Maintenance for mechanism seal

- 机构密封润滑应清洁无固体颗粒。
The lubrication of mechanism seal should clean without solid particle.
- 严禁机构密封在干磨情况下工作。
Prohibiting mechanism seal working in the dry grinding condition.
- 起动前应先盘动泵（电机）几圈，以免突然起动造成石墨环断裂损坏。
Start pump (motor) for several circle before starting, to avoid graphite ring to be damaged.
- 密封泄漏允差3滴/分，否则应检修。
The leakage tolerance of mechanical seal is about 3 drop/minute, or else it should be checked.

S型泵装配与拆卸、安装说明

Assemble and disassemble & instruction of installation

■ 装配与拆卸Assemble and disassemble

- 装配转子部件：依次将叶轮、叶轮螺母、轴套、填料套、填料环、填料压盖、挡水圈、轴承部件装在泵轴上，并套上双吸密封环，然后装上联轴器。

Assemble the rotor's parts: Mounting the impeller, impeller nut, shaft sleeve, stuffing sleeve, stuffing ring, stuffing gland, water retaining ring, bearing on the pump shaft in turn, and putting on dual-suction seal ring, then installing the coupling.

- 将转子部件装在泵体上，调整叶轮的轴向位置到双吸密封环的中间加以固定，将轴承体压盖同固定螺钉紧固。
- 装上填料，放好中开面纸垫，盖上泵盖打紧螺母柱销后，拧紧泵盖螺母，最后装上填料压盖。但不要将填料压得太紧，填料过紧会使轴套发热，耗费功率较大，也不要压得太松，过松会使液体渗漏大，水泵效率降低。装配完成后，用手转动泵轴，没有擦碰现象，转动比较轻滑均匀即可，拆卸可按上述装配顺序相反进行。

Mount the rotor on the pump casing, adjusting the impeller to have its axial position in the middle of the dual-suction seal ring and then fixed, then fixing the gland of bearing's body with the terminal screw.

Put on the stuffing, the paper pad on the middle opened surface and the pump cover and tighten the threaded-tail conical pin first and the pump's cover nut, then mounting the stuffing gland. But do not press the stuffing too tightly, otherwise the shaft sleeve may get heated to leave a bigger power consumption; while not too loose, or else may result in a big leakage of liquid and reduced pump efficiency. After assembly, move the pump shaft by hand, it should be smooth and uniform without rubbing, disassembly can be made with the above steps contrary.

■ 安装说明The instruction of installation

- 检查水泵和电动机应无损坏；
- 水泵的安装高度，加上吸入管路的水力损失，及其速度能，不得大于样本规定的允许吸上真空高度值。基础尺寸应符合泵机组的安装尺寸；

Check pump and motor to see if there are any damages with them.

The installation height of the pump plus the hydraulic loss of the suction pipeline and its speed energy is just the NPSHa of the unit, which should be higher than NPSHr. The dimension of the basis should be in line with those of installation of the pump unit.

安装顺序Installation sequences:

1.将水泵放在埋有地脚螺栓的混凝土基础上，有调整其间的楔型垫块的方法校正水平，并适当拧紧地脚螺栓，以防走动；

Place the pump on the concrete basis with built-in foot bolts, correct the levelness with the method adjusting the wedge cushion block and properly tighten the bolts to prevent them from displacement;

2.在基础与泵地脚之间灌注混凝土；

Grout concrete between the basis and the pump foot;

3.待混凝土干固后，拧紧地脚螺栓，并重新检查水泵的水平度；

After the concrete gets solidified, tighten the foot bolts and check the pump's levelness again;

4.校正电动机轴与泵轴的同心度。使两轴成一直线，在两轴外圆上的同轴度允差为0.1mm，端面间隙沿圆周的不均匀度允差0.3mm（在联接进出水管路及试运行后再分别校正一遍，仍应符合上述要求）；

Correct the concentricity between the axles of pump and motor to have them in a straight line. The allowed tolerance of the non-concentricity of the outer circles of two couplings is 0.1mm and the one of the non-uniform end-surface intervals along with the circumference is 0.3mm(another correction after connecting inlet and outlet pipelines and trial movement, the above requirement should also be met with);

5.在检查电动机转向与水泵转向一致后，装上联轴器及联接柱销。

After finding out the rotating direction of the motor is identical to that of the pump, mounting the link pin of the coupling.

- 进出水管路应另设支架支撑，不得借泵体支撑；
- 水泵与管路之间的结合面，应保证良好的气密性，尤其是进水管路，应严格保证不漏气，并且在装置上应无窝存空气的可能；
- 如水泵安装在进水水位上时，为了灌泵起动，一般可装底阀。也可采用真空引水的方法；
- 水泵与出水管路之间一般需装闸阀和止回阀（扬程小于20mm的可不用），止回阀装在闸阀后面。

Both inlet and outlet pipelines should be supported by a separate stand and not by the pump body;

A good air tightness of the combined surface between pump and pipeline should be kept, especially the inlet pipeline, it must be guaranteed without air leak and without the possibility for air to be nested on the unit;

In general, a foot valve can be mounted if the pump is mounted above the water level of the inlet so as to start the pump with priming, it can also use the way of vacuum pump water leading;

In general, gate valve and check valve are required to be mounted in the outlet pipeline of the pump(unnecessary for those of a head less than 20m), with the check valve mounted after the gate valve;

- 以上所述的安装方法是指不配带公共底座的水泵机组；

The above mentioned methods of installation mean the pump without a common foundation;

- 安装配带公共底座的泵，用调整底座与混凝土基础之间的楔形垫铁来校正机组的水平。然后在其间灌注混凝土，其安装原则与要求，和不配带公共底座的机能相同。

For the pump with a common foundation, use the wedge iron-pad between foundation and concrete to correct the levelness of the unit, then grout concrete between them. The installation principle and requirement are the same as those for the pump without a common foundation.

S型泵故障原因及排除方法

Malfunction reason and troubleshooting for S type pump

■ 故障原因及排除方法

常见故障	原因分析	处理方法
水泵不出水	a.进出口阀门未打开，进出管道阻塞，叶轮流道阻塞。 b.电机运行方向不对，电机缺相转速很慢。 c.吸入管漏气。 d.没有灌满液体，泵腔有空气。 E.进口供水不定，吸程过高，底阀漏水。 f.管路阻力过大，选型不当。	A.检查，去除阻塞物。 b.调整电机方向，紧固电机接线。 c.拧紧各密封面，排除空气。 d.打开泵上盖或打开排气阀，排除空气。 e.停机检查、调整（并网自来水管和带吸程使用易出现此现象）。 f.减少管路弯道，重新选泵
水泵流量不足	a.先按1.原因检查。 b.管道、泵叶轮流道部分阻塞，水垢沉积，阀门开度不足。 c.电压偏低。 d.叶轮磨损。	A.先按1.排除。 b.去除阻塞物，重新调整阀门开度。 c.稳压。 d.更换叶轮
功率过大	a.超过额定流量使用。 b.吸程过高。 c.泵轴承磨损。	a.调节流量，关小出口阀门。 b.降底吸程。 c.更换轴承。
杂音振动	a.管路支撑不稳。 b.液体混有气体。 C.产生汽蚀。 d.轴承损坏。 e.电机超载，发热运行。	a.稳固管路。 b.提高吸入压力、排气。 c.降低真空度。 d.更换轴承。 e.调整按5。
电机发热	a.流量过大，超载运行。 b.碰擦。 c.电机轴承损坏。 d.电压不足。	A.关小出口阀。 b.检查排除。 c.更换轴承。 d.稳压。
水泵漏水	a.机械密封磨损。 b.泵体有砂孔或破裂。 c.密封面不平整。 d.安装螺栓松懈。	a.更换。 B.焊补或更换。 c.修整。 d.紧固。

S型泵故障原因及排除方法

Malfunction reason and troubleshooting for S type pump

■ Malfunction reason and troubleshooting

Malfunction	Reason	Troubleshooting
Water pump couldn't discharge water	<ul style="list-style-type: none"> a. The valve of inlet and outlet isn't open, inlet pipeline and flow passage of impeller is blocked; b. The revolving direction of motor isn't right, motor is short of phase and revolving speed is slow; c. Suction pipe leaks gas; d. Pump isn't full of liquid, there is air in pump chamber; e. There isn't enough water in inlet, the suction head is too high and the bottom valve leaks water; f. The resistance in pipeline is too large, the type of pump isn't suitable. 	<ul style="list-style-type: none"> a. Check and remove the block; b. Adjust the direction of motor, tighten the joint of Motor, and check electrical part; c. Tighten every seal surface and discharge air; d. Open pump upper cover or open discharge valve To discharge air; e. Stop unit to check and adjust; f. Reduce elbow of pipeline, select pump again.
Flow capacity of water pump isn't enough	<ul style="list-style-type: none"> a. Check it according to the reason that water pump Can't discharge water; b. Pipeline, flow passage of pump or impeller is blocked, sediment of scale, valve aperture isn't enough; c. Voltage is too lower; D. Impeller is wore out. 	<ul style="list-style-type: none"> a. Remove it according to the reason that water Pump can't discharge water; b. Remove block, adjust valve aperture again; c. Steady voltage; d. Replace impeller.
The power is too large	<ul style="list-style-type: none"> a. It is used over rated flow capacity; b. The suction head is too high; c. Pump bearing is wore out. 	<ul style="list-style-type: none"> a. Adjust flow capacity, turn outlet valve down; b. Reduce it; C. Replace bearing.
Noise and shake	<ul style="list-style-type: none"> a. The support of pipeline isn't stable; b. There is gas in liquid; c. There is NPSH; d. The bearing is wore out; E. The motor operates over load. 	<ul style="list-style-type: none"> a. Reinforce pipeline; b. Increase suction pressure, discharge gas; c. Reduce the degree of vacuum; D. Replace bearing;
The motor is heat	<ul style="list-style-type: none"> a. The flow capacity is too large, and it operates over Load; b. There is friction partly; c. The bearing of motor is damaged; d. The voltage isn't enough. 	<ul style="list-style-type: none"> A. Turn outlet valve down; b. Check and remove; c. Replace the bearing; d. Steady voltage.
Water pump leaks water	<ul style="list-style-type: none"> A. Mechanical seal is damaged; b. There is sand hole or cracking in pump; c. Seal surface isn't smooth; d. Installed bolt is loose. 	<ul style="list-style-type: none"> a. Replace it; b. Weld or replace it; c. Repair it; D. Tighten it.